



ULTRA-GRIP

INTERNATIONAL

Your Engineered Workholding Solution

Design and Manufacturer of Precision Workholding Products

- Power Chucks
- Diaphragm Chucks
- Arbors
- Retractable Jaw Chucks
- Pitch-Line Gear Chucks
- Thru-Hole Chucks
- Pin Chucks
- Face Clamp Chucks
- Rotating Cylinders
- Large Diameter Chucks

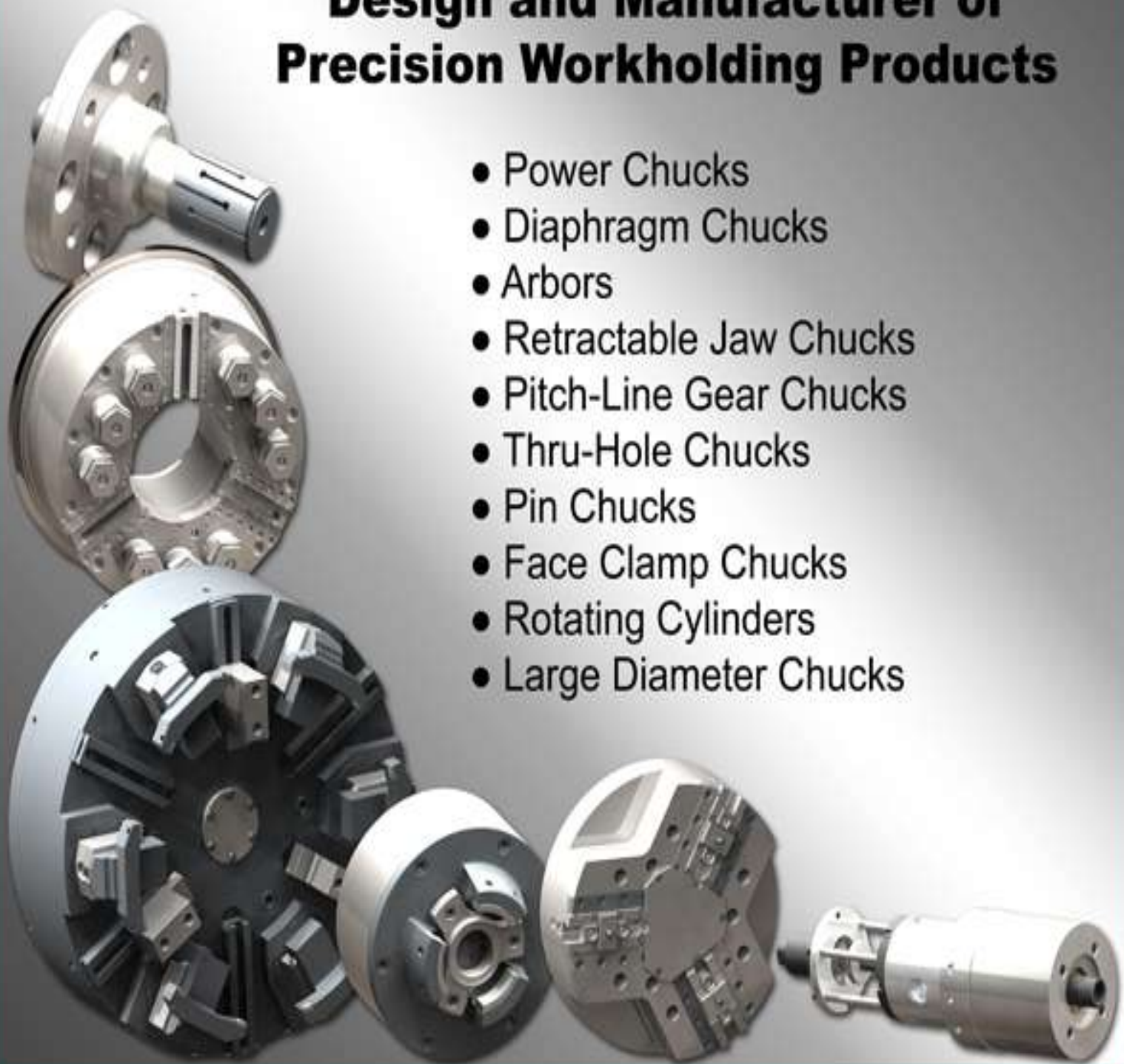

Three-M and Ultra-Grip

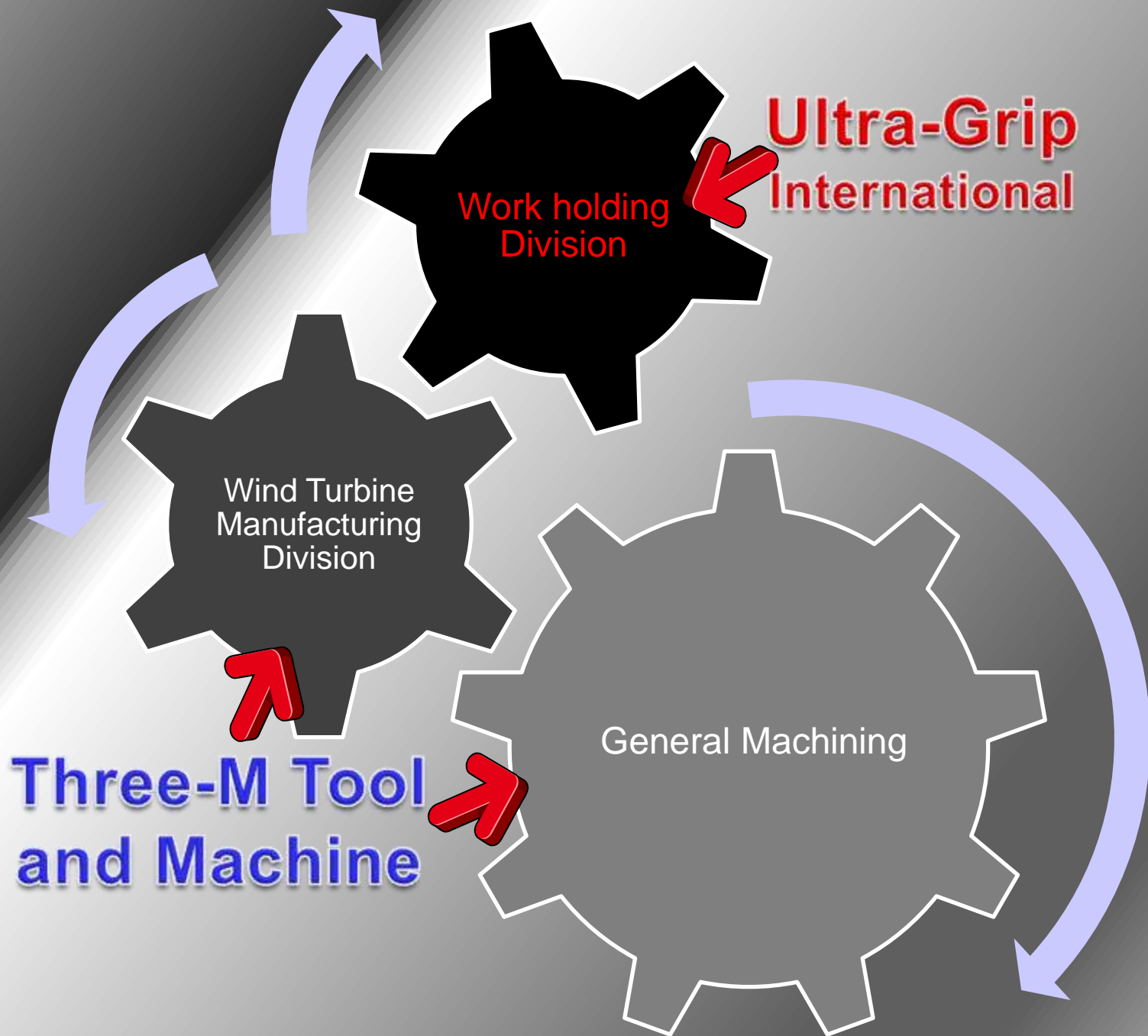

Company Profile

- Privately held company established in 1990.
- Design and Manufacture standard and special work holding products.
- Over 150 years combined engineering experience.
- Combined forces with Three-m Tool and Machine for the manufacture and assembly of our products.
- All components are designed and manufactured in house, allowing complete control over the quality of our products.

Sales

- Ultra-Grip is an engineering driven company.
- Our sales team have years of engineering experience.
 - This allows our sales team to provide our customers with on-site solutions to their work holding requirements.
- National sales coverage including Mexico.
- Inside sales and quoting have years of Design and Detailing experience.
 - Concept sketches on all special applications are available.

Sales (cont.)

- Visit www.ultra-grip.com for all of our sales contact and product information.
 - Inside and outside sales contacts.
 - Product information
 - View our products online.
 - Download a complete catalog of all of our products.



ENGINEERING



- Over 150 years combined Engineering experience
- Utilizing Parametric Engineering to ensure the highest product quality
- Design reviews performed on all designs
- Engineering driven company



SolidWorks solid modeling software



- Parametric Engineering
 - The design and all subsequent details are linked and automatically updated.
 - If a detail is changed all parent designs are updated automatically.
 - The model can be moved to show interferences, total movement of chuck.
 - Balancing can be determined from vector analysis.
- Finite element analysis and centrifugal forces calculations can be performed inherit to the model.
- Using the latest 3D CAD software our engineers will design to your engineering requirements.
- Our project engineers work directly with your staff to resolve any issues which may arise during and after project completion.
- Design integrity is then carried forward to manufacturing via. CAD/CAM.

Engineering (cont.)

- Design for Manufacture (DFM)
 - Once the design is complete it does not get thrown “over the wall” for manufacturing to complete.
 - Engineering and manufacturing work as a team to resolve issues up front during the design process and throughout the manufacturing process.
 - Design Failure Modes and Effects Analysis (FMEA) are performed on each design.
 - Customer approval stage assures customer interface on all design approvals.



THREE M

Tool & Machine, Inc.

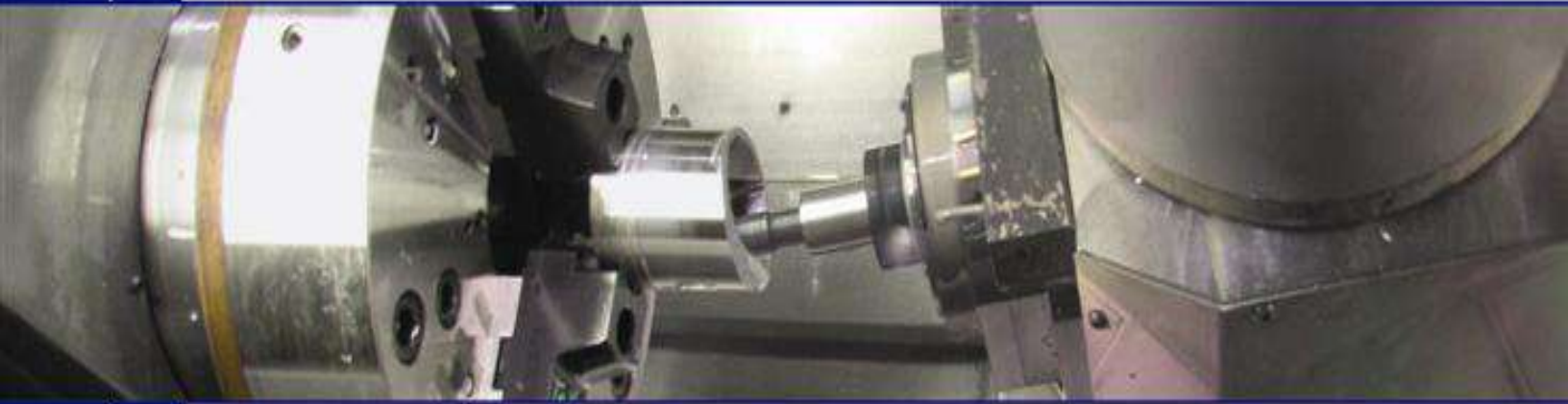

Applying Tomorrows Technology Today

- **Milling** - Up to 196"
- **Turning** - Up to 100"
- **Grinding** - Up to 72"
- **EDM** - Wire and Sinkers
- **Inspection** - Up to 160"

Manufacturing

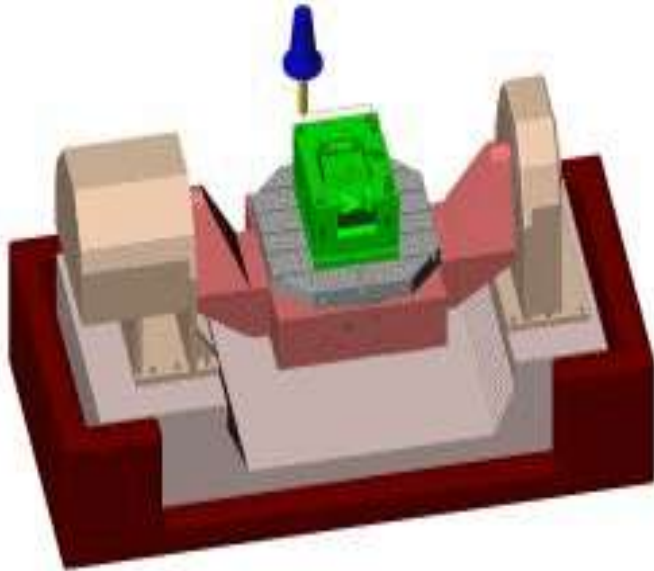

- Three-M tool and machine established in 1971.
- CAD/CAM technology
 - Committed to using the latest and most technologically advanced software, using Esprit and MasterCAM.
- CNC machining
 - Up to 96", we have a large, well-equipped facility featuring CNC milling, turning, and grinding.



Manufacturing (cont.)



- EDM
 - Equipped with the latest EDM's. Capable of close tolerance.
- CMM inspection services
 - DEA and Zeiss CMM capable of X,Y,Z measuring range of 160" x 100" x 72".
- Quality policy
 - Three-M Tool and Machine will provide high-value products and services that meet or exceed the needs of customers by continuously improving.



SERVICE / ASSEMBLY



- Complete in-house assembly
- State-of-the-art testing capabilities
- Service team works direct with customer for quicker response
- In-house Balancing





ULTRA-GRIP

INTERNATIONAL

Your Engineered Workholding Solution



Product diversification is key to remaining a leader in the Workholding industry.



- Power Chucks
- Diaphragm Chucks
- Arbors
- Retractable Jaw Chucks
- Pitch-Line Gear Chucks
- Thru-Hole Chucks
- Pin Chucks
- Face Clamp Chucks
- Rotating Cylinders
- Large Diameter Chucks



Six Jaw Pressure Equalizing Ball-Grip™ Power Chuck

- ❑ Effectively grips thin wall work pieces with minimal distortion at a single chucking pressure
- ❑ Eliminates the need for costly machining options
- ❑ A six jaw chuck that uniformly distributes a 3.6:1 power ratio to the work piece
- ❑ Six uniquely connected jaws distribute clamping force to 12 equally spaced contact points on the work piece
- ❑ For first operation each jaw has two replaceable carbide inserts that distributes an equalized portion of the total gripping force at the contact points
- ❑ Eliminates marks on parts in secondary operations with smooth chuck jaws



Additional Power Chuck Features

Sealed Design

Eliminates costly maintenance and down time, increasing machine time, productivity and profits

Ball Joint Construction

Power mechanism operates within a sealed unit of high pressure lubricant

High Power Ratio

Higher gripping force with less input resulting in longer chuck life

Jaw Travel

Increased Jaw travel enhances part loading and tolerance variations

Pullback Action

Stabilizes part against work stop providing positive location and control of critical machining dimensions

Jaw Swivel

Compensates for part variation insuring 12 point jaw contact

Differential Chuckings

Chuck allows for High-Low pressure chucking

Customer Assistance

Ultra Grip's trained personnel provide immediate on-site customer service

QC Jaw Mountings

Optional Quick Change Jaw Mounting available for rapidly changing work piece tooling and eliminating screw removal

8155 Richardson Road Walled Lake, Michigan 48390 248.363.0982 Fax 248.363.4949

e-mail: sales@ultra-grip.com Website: www.ultra-grip.com



Manufactured & Assembled in the USA



Six Jaw Pressure Equalizing Ball-Grip™ Power Chuck

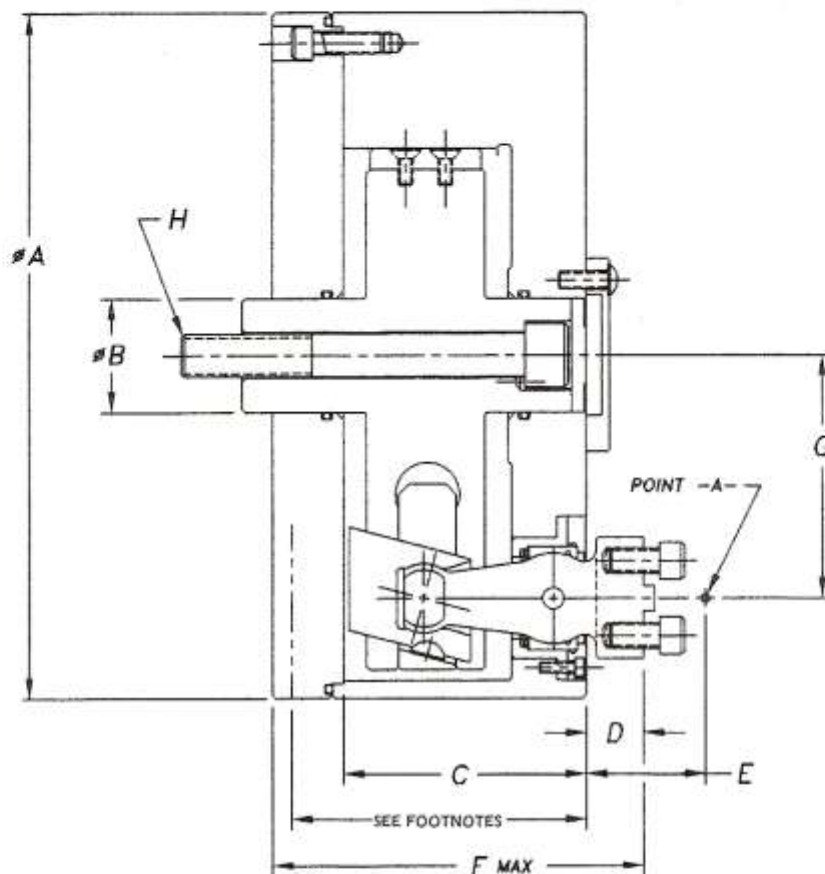

CHUCK SIZE	8"	10"	12"	15"	18"	22"	26"	30"	
SIX JAW EQUALIZING CHUCK ASSEMBLY	UBG 8006	UBG 10006	UBG 12006	UBG 15006	UBG 18006	UBG 22006	UBG 26006	UBG 30006	
DIMENSIONS	A	8.625	10.005	12.005	15.245	18.005	22.005	26.005	30.005
	B	1.500	1.500	2.000	2.500	3.500	3.500	3.500	3.500
	C	2.444	3.875	4.232	5.375	5.610	5.610	7.312	7.312
	D	.67	.87	1.00	1.22	1.50	1.50	2.063	2.063
	E	1.60	1.83	2.08	2.61	2.94	2.94	3.938	3.938
	F	4.334	5.994	6.469	8.164	8.735	8.735	11.244	11.244
	G	3.1890	3.4375	4.2500	5.5000	6.2500	8.0000	9.1875	11.1875
	H	5/8	5/8	3/4	1.00	1.00	1.00	1.00	1.00
MAX. DRAWBAR IN LBS. OF FORCE	5,000	10,500	12,000	16,000	18,000	18,000	20,000	20,000	
TOTAL DRAWBAR TRAVEL ~ MINIMUM	.38	.82	.88	.96	.96	.96	1.00	1.00	
TOTAL JAW TRAVEL AT POINT -A- (DIAMETRICAL TRAVEL)	.292	.440	.515	.576	.617	.617	.600	.600	

- MINIMUM CHUCK HEIGHT TO BE DETERMINED UPON RECEIPT OF MACHINE SPINDLE INFORMATION
- LARGER CHUCK SIZES AVAILABLE UPON REQUEST

Ball-Grip™ Power Chucks

Ultra-Grips Ball-Grip™ Power Chucks Are Available In a Variety of Designs

- ❑ **Two & Three Jaw Centralizing Ball-Grip Power Chucks**
Chuck centers the work piece
- ❑ **Two & Three Jaw Compensating Ball-Grip Power Chucks**
Chuck design enables the actuator to float permitting the jaws to grip work piece independent of the chuck center. Initial work piece location is established on a previously machined surface while chuck jaws securely grip on an eccentric diameter or irregular surface.
- ❑ **Two & Three Jaw Centralizing/Compensating Ball-Grip Power Chucks**
One chuck can be used for either chucking mode. Centralizing mode for roughing operation and compensating mode for secondary operation. Chuck can be changed to either mode in a matter of minutes.
- ❑ **Four Jaw Centralizing Equalizing Ball-Grip Power Chucks**
Chucks centers work piece in two planes with jaws distributing clamping force equally to eight contact points on the work piece.



Power Chuck Features

Sealed Design

Eliminates costly maintenance and down time, increasing machine time, productivity and profits

Ball Joint Construction

Power mechanism operates within a sealed unit of high pressure lubricant

High Power Ratio

Higher gripping force with less input resulting in longer chuck life

Jaw Travel

Increased Jaw travel enhances part loading and tolerance variations

Pullback Action

Stabilizes part against work stop providing positive location and control of critical machining dimensions

Jaw Swivel

Compensates for part variation insuring 2 point contact with each jaw.

External/Internal Chucking

Optional Quick change from external to internal chucking mode available

Customer Assistance

Ultra Grip's trained personnel provide immediate on-site customer service

QC Jaw Mountings

Optional Quick Change Jaw Mounting available for rapidly changing work piece tooling and eliminating screw removal



Four Jaw Centralizing Equalizing Ball-Grip™ Chucks

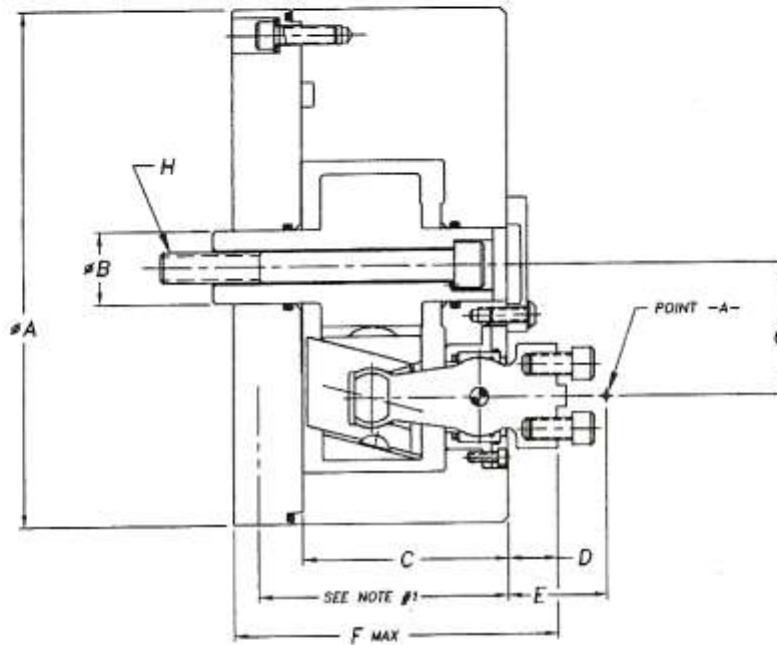

CHUCK SIZE	10"	23"	
FOUR JAW CENTRALIZING/EQUALIZING CHUCK ASSEMBLY	UBG 10004	UBG 23004	
DIMENSIONS	A	10.50	23.00
	B	1.50	3.00
	C	4.23	5.61
	D	1.00	1.50
	E	2.30	2.94
	F	6.59	8.76
	G	2.68	7.75
	H	5/8	1.00
MAX. DRAWBAR IN LBS. OF FORCE	6,500	16,000	
TOTAL DRAWBAR TRAVEL - MINIMUM	.79	.90	
TOTAL JAW TRAVEL AT POINT -A- (DIAMETRICAL TRAVEL)	.540	.620	

*Note #1 MINIMUM CHUCK HEIGHT TO BE DETERMINED UPON RECEIPT OF MACHINE SPINDLE INFORMATION

Two Jaw Centralizing Ball-Grip™ Chucks

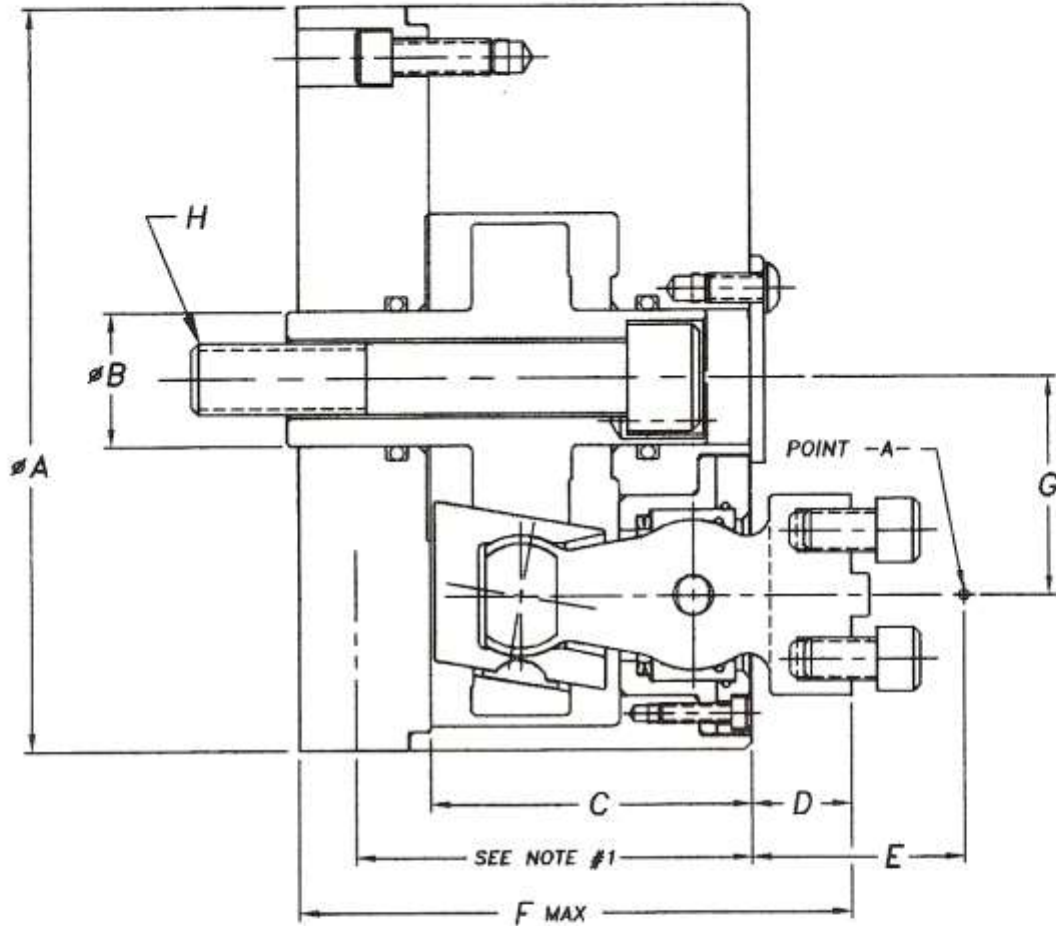

CHUCK SIZE	6"	7"	8"	9"	10"	12"	15"	18"	21"	24"	30"	33"	
TWO JAW CENTRALIZING CHUCK ASSEMBLY	UBG 6010	UBG 7010	UBG 8010	UBG 9010	UBG 10010	UBG 12010	UBG 15010	UBG 18010	UBG 21010	UBG 24010	UBG 30010	UBG 33010	
DIMENSIONS	A	6.50	7.75	8.25	9.50	10.00	12.00	15.00	18.00	21.00	24.00	30.00	33.01
	B	1.18	1.18	1.25	1.25	1.50	1.50	2.25	3.50	3.50	3.50	3.50	3.50
	C	2.76	2.76	3.21	3.21	4.00	4.00	4.56	4.56	4.56	5.87	5.87	5.87
	D	.86	.86	1.00	1.00	1.22	1.22	1.50	1.50	1.50	2.00	2.00	2.00
	E	1.83	1.83	2.08	2.08	2.61	2.61	2.94	2.94	2.94	3.88	3.88	3.88
	F	4.75	.75	5.52	5.52	6.46	6.59	7.56	7.56	7.56	9.59	9.62	9.62
	G	1.906	2.528	2.437	3.062	2.812	3.812	4.750	6.250	7.750	8.000	11.000	12.500
	H	5/8	5/8	5/8	5/8	5/8	5/8	1.00	1.00	1.00	1.00	1.00	1.00
MAX. DRAWBAR IN LBS. OF FORCE	3,500	3,500	4,500	4,500	6,000	6,000	8,750	8,750	8,750	14,000	14,000	14,000	
TOTAL DRAWBAR TRAVEL - MINIMUM	.74	.74	.88	.88	1.12	1.12	1.38	1.38	1.38	1.24	1.24	1.24	
TOTAL JAW TRAVEL AT POINT -A- (DIAMETRICAL TRAVEL)	.37	.37	.45	.45	.60	.60	.75	.75	.75	.75	.75	.75	

*Note #1 MINIMUM CHUCK HEIGHT TO BE DETERMINED UPON RECEIPT OF MACHINE SPINDLE INFORMATION

- SHOWN ABOVE IS AN EXTERNAL GRIP CENTRALIZING CHUCK.
- MOST CHUCK SIZES ARE AVAILABLE AS STANDARD, IN EXTERNAL, INTERNAL, CENTRALIZING, COMPENSATING AND "CENTRALIZING-COMPENSATING".

Two Jaw Compensating Ball-Grip™ Chucks

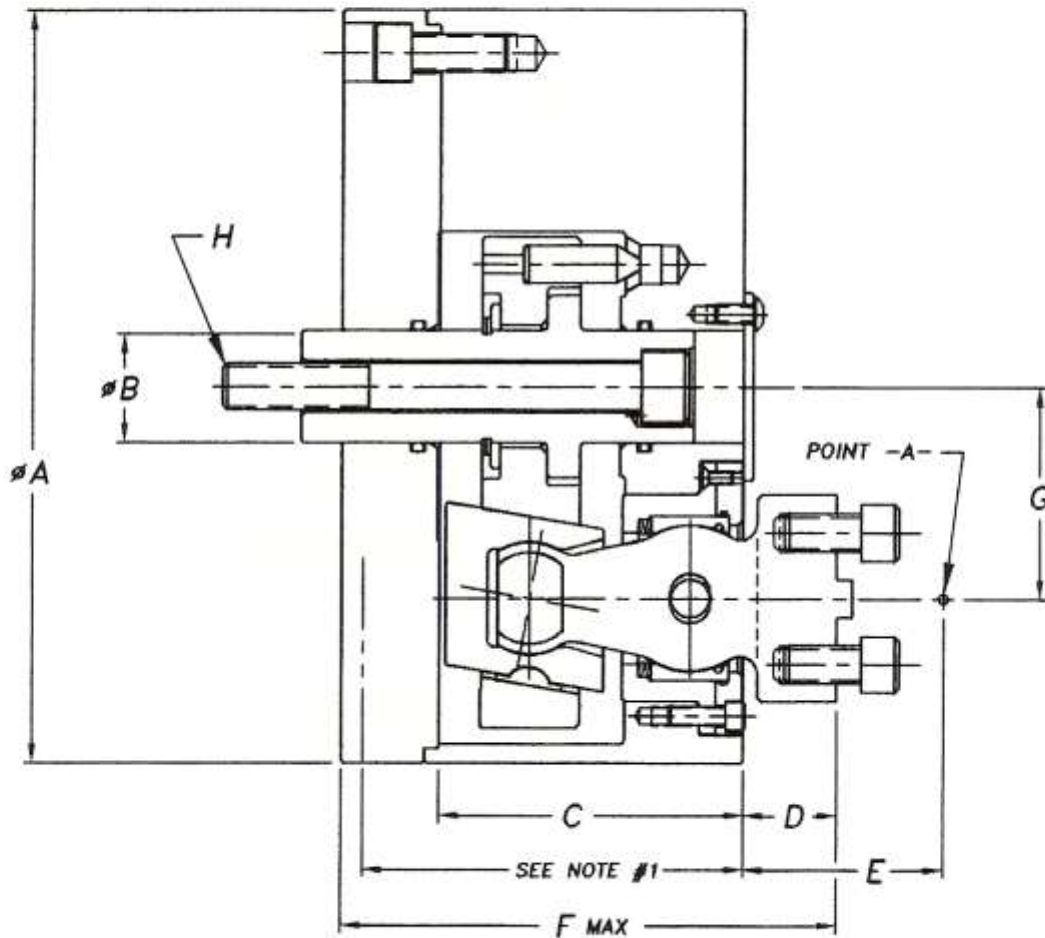

CHUCK SIZE	6"	7"	8"	9"	10"	12"	15"	18"	21"	24"	30"	33"	
TWO JAW COMPENSATING CHUCK ASSEMBLY	UBG 6012	UBG 7012	UBG 8012	UBG 9012	UBG 10012	UBG 12012	UBG 15012	UBG 18012	UBG 21012	UBG 24012	UBG 30012	UBG 33012	
DIMENSIONS	A	6.50	7.75	8.25	9.50	10.00	12.00	15.00	18.00	21.00	24.00	30.00	33.01
	B	1.18	1.18	1.25	1.25	1.50	1.50	2.25	3.50	3.50	3.50	3.50	3.50
	C	2.76	2.76	3.21	3.21	4.00	4.00	4.56	4.56	4.56	5.87	5.87	5.87
	D	.86	.86	1.00	1.00	1.22	1.22	1.50	1.50	1.50	2.00	2.00	2.00
	E	1.83	1.83	2.08	2.08	2.61	2.61	2.94	2.94	2.94	3.88	3.88	3.88
	F	4.75	.75	5.52	5.52	6.46	6.59	7.56	7.56	7.56	9.59	9.62	9.62
	G	1.906	2.528	2.437	3.062	2.812	3.812	4.750	6.250	7.750	8.000	11.000	12.500
H	5/8	5/8	5/8	5/8	5/8	5/8	1.00	1.00	1.00	1.00	1.00	1.00	
MAX. DRAWBAR IN LBS. OF FORCE	3,500	3,500	4,500	4,500	6,000	6,000	8,750	8,750	8,750	14,000	14,000	14,000	
TOTAL DRAWBAR TRAVEL - MINIMUM	.74	.74	.88	.88	1.12	1.12	1.38	1.38	1.38	1.24	1.24	1.24	
TOTAL JAW TRAVEL AT POINT -A- (DIAMETRICAL TRAVEL)	.37	.37	.45	.45	.60	.60	.75	.75	.75	.75	.75	.75	

*Note #1 MINIMUM CHUCK HEIGHT TO BE DETERMINED UPON RECEIPT OF MACHINE SPINDLE INFORMATION

● SHOWN ABOVE IS AN EXTERNAL GRIP COMPENSATING CHUCK.

● MOST CHUCK SIZES ARE AVAILABLE AS STANDARD, IN EXTERNAL, INTERNAL, CENTRALIZING, COMPENSATING AND "CENTRALIZING-COMPENSATING".



8155 Richardson Road Walled Lake, Michigan 48390 248.363.0982 Fax 248.363.4949

e-mail: sales@ultra-grip.com Website: www.ultra-grip.com

Manufactured & Assembled in the USA

Three Jaw Centralizing Ball-Grip™ Chucks

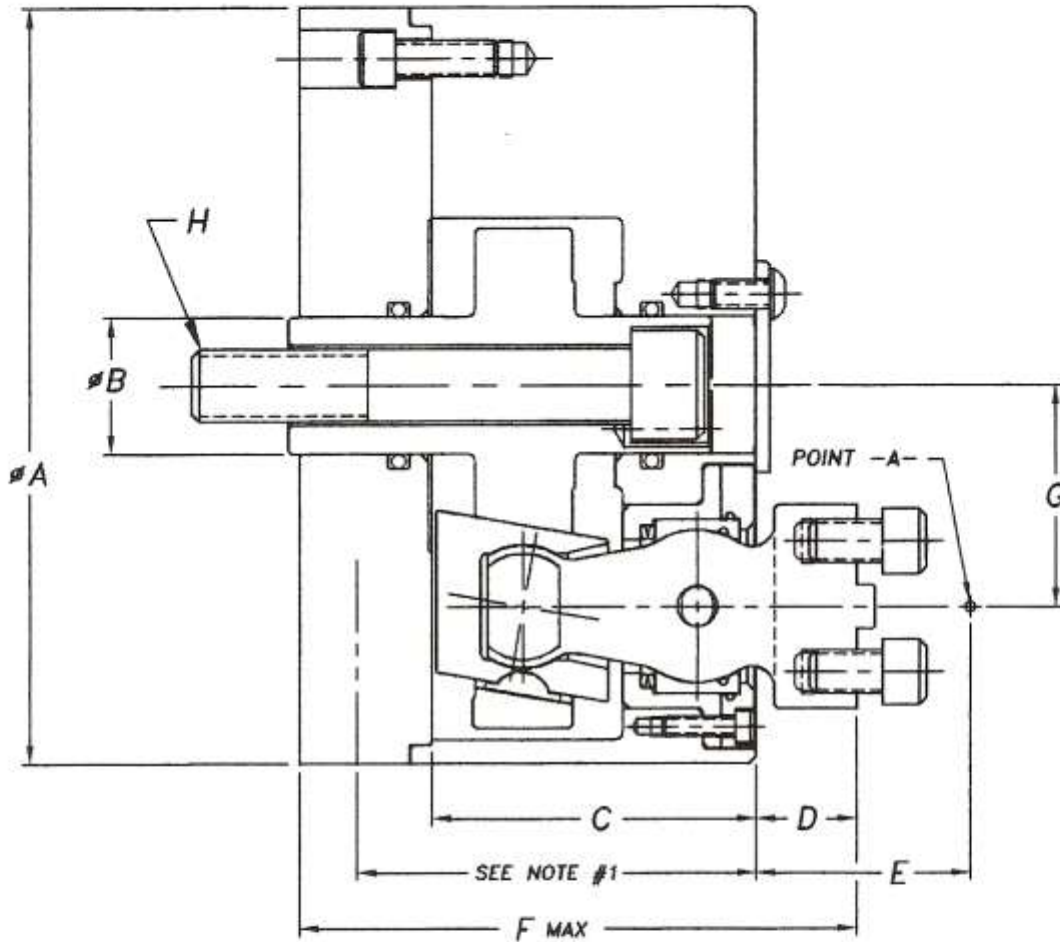

CHUCK SIZE	6"	7"	8"	9"	10"	12"	15"	18"	21"	24"	30"	33"	
THREE JAW CENTRALIZING CHUCK ASSEMBLY	UBG 6000	UBG 7000	UBG 8000	UBG 9000	UBG 10000	UBG 12000	UBG 15000	UBG 18000	UBG 21000	UBG 24000	UBG 30000	UBG 33000	
DIMENSIONS	A	6.50	7.75	8.25	9.50	10.00	12.00	15.00	18.00	21.00	24.00	30.00	33.00
	B	1.18	1.18	1.25	1.25	1.50	1.50	2.25	3.50	3.50	3.50	3.50	3.50
	C	2.76	2.76	3.21	3.21	4.00	4.00	4.56	4.56	4.56	5.87	5.87	5.87
	D	.86	.86	1.00	1.00	1.22	1.22	1.50	1.50	1.50	2.00	2.00	2.00
	E	1.83	1.83	2.08	2.08	2.61	2.61	2.94	2.94	2.94	3.88	3.88	3.88
	F	4.75	.75	5.52	5.52	6.46	6.59	7.56	7.56	7.56	9.59	9.62	9.62
	G	1.906	2.528	2.437	3.062	2.812	3.812	4.750	6.250	7.750	8.000	11.000	12.500
	H	5/8	5/8	5/8	5/8	5/8	5/8	1.00	1.00	1.00	1.00	1.00	1.00
MAX. DRAWBAR IN LBS. OF FORCE	5,000	5,000	6,750	6,750	10,000	10,000	12,500	12,500	12,500	20,000	20,000	20,000	
TOTAL DRAWBAR TRAVEL - MINIMUM	.74	.74	.88	.88	1.12	1.12	1.38	1.38	1.38	1.24	1.24	1.24	
TOTAL JAW TRAVEL AT POINT -A- (DIAMETRICAL TRAVEL)	.37	.37	.45	.45	.60	.60	.75	.75	.75	.75	.75	.75	

*Note #1 MINIMUM CHUCK HEIGHT TO BE DETERMINED UPON RECEIPT OF MACHINE SPINDLE INFORMATION

- SHOWN ABOVE IS AN EXTERNAL GRIP CENTRALIZING CHUCK.
- MOST CHUCK SIZES ARE AVAILABLE AS STANDARD, IN EXTERNAL, INTERNAL, CENTRALIZING, COMPENSATING AND "CENTRALIZING-COMPENSATING".

Three Jaw Compensating Ball-Grip™ Chucks

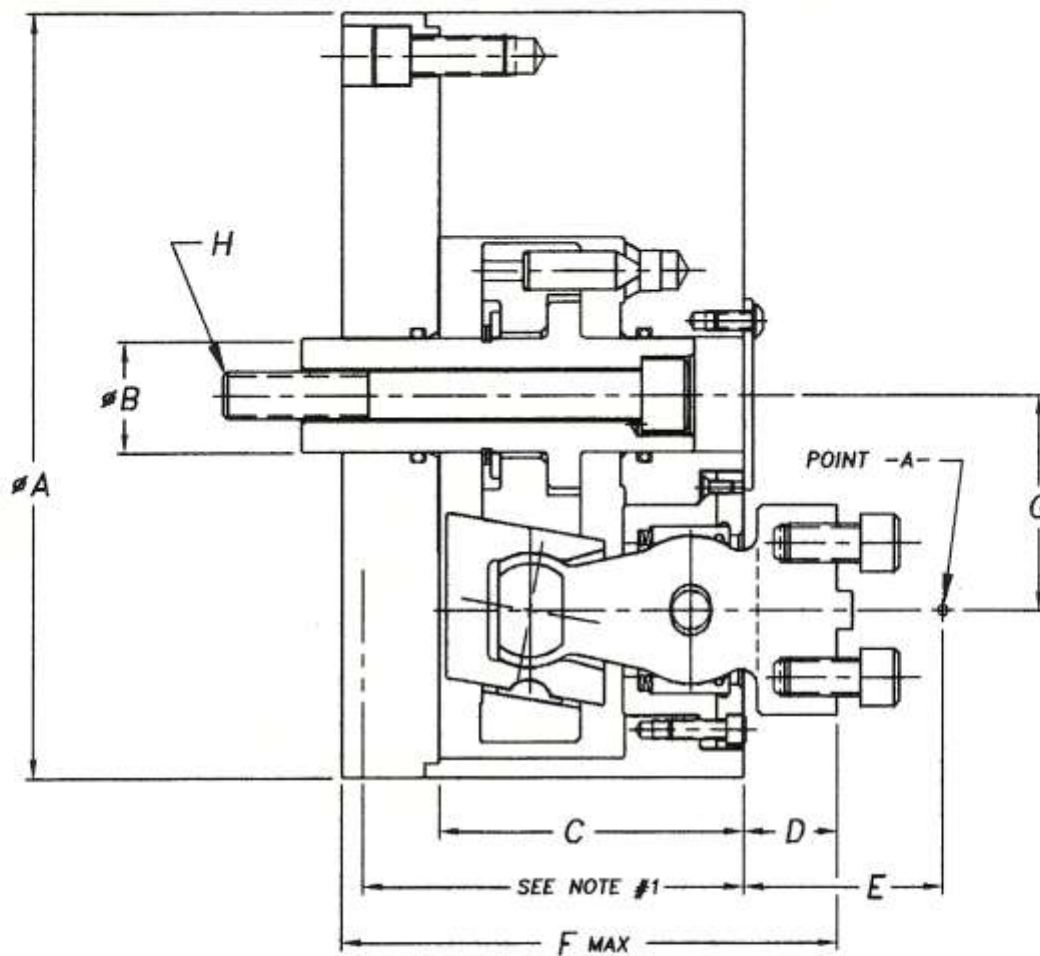

CHUCK SIZE THREE JAW COMPENSATING CHUCK ASSEMBLY	6"	7"	8"	9"	10"	12"	15"	18"	21"	24"	30"	33"	
	UBG 6002	UBG 7002	UBG 8002	UBG 9002	UBG 10002	UBG 12002	UBG 15002	UBG 18002	UBG 21002	UBG 24002	UBG 30002	UBG 33002	
DIMENSIONS	A	6.50	7.75	8.25	9.50	10.00	12.00	15.00	18.00	21.00	24.00	30.00	33.01
	B	1.18	1.18	1.25	1.25	1.50	1.50	2.25	3.50	3.50	3.50	3.50	3.50
	C	2.76	2.76	3.21	3.21	4.00	4.00	4.56	4.56	4.56	5.87	5.87	5.87
	D	.86	.86	1.00	1.00	1.22	1.22	1.50	1.50	1.50	2.00	2.00	2.00
	E	1.83	1.83	2.08	2.08	2.61	2.61	2.94	2.94	2.94	3.88	3.88	3.88
	F	4.75	.75	5.52	5.52	6.46	6.59	7.56	7.56	7.56	9.59	9.62	9.62
	G	1.906	2.528	2.437	3.062	2.812	3.812	4.750	6.250	7.750	8.000	11.000	12.500
	H	5/8	5/8	5/8	5/8	5/8	5/8	1.00	1.00	1.00	1.00	1.00	1.00
MAX. DRAWBAR IN LBS. OF FORCE	5,000	5,000	6,750	6,750	10,000	12,000	12,500	12,500	12,500	20,000	20,000	20,000	
TOTAL DRAWBAR TRAVEL - MINIMUM	.74	.74	.86	.88	1.12	1.12	1.38	1.38	1.38	1.24	1.24	1.24	
TOTAL JAW TRAVEL AT POINT -A- (DIAMETRICAL TRAVEL)	.37	.37	.45	.59	.59	.75	.75	.75	.75	.75	.75	.75	

*Note #1 MINIMUM CHUCK HEIGHT TO BE DETERMINED UPON RECEIPT OF MACHINE SPINDLE INFORMATION

- SHOWN ABOVE IS AN EXTERNAL GRIP COMPENSATING CHUCK.
- MOST CHUCK SIZES ARE AVAILABLE AS STANDARD, IN EXTERNAL, INTERNAL, CENTRALIZING, COMPENSATING AND "CENTRALIZING-COMPENSATING".



8155 Richardson Road Walled Lake, Michigan 48390 248.363.0982 Fax 248.363.4949
e-mail: sales@ultra-grip.com Website: www.ultra-grip.com

Manufactured & Assembled in the USA

Three Jaw Platform Style Ball-Grip™ Power Chucks

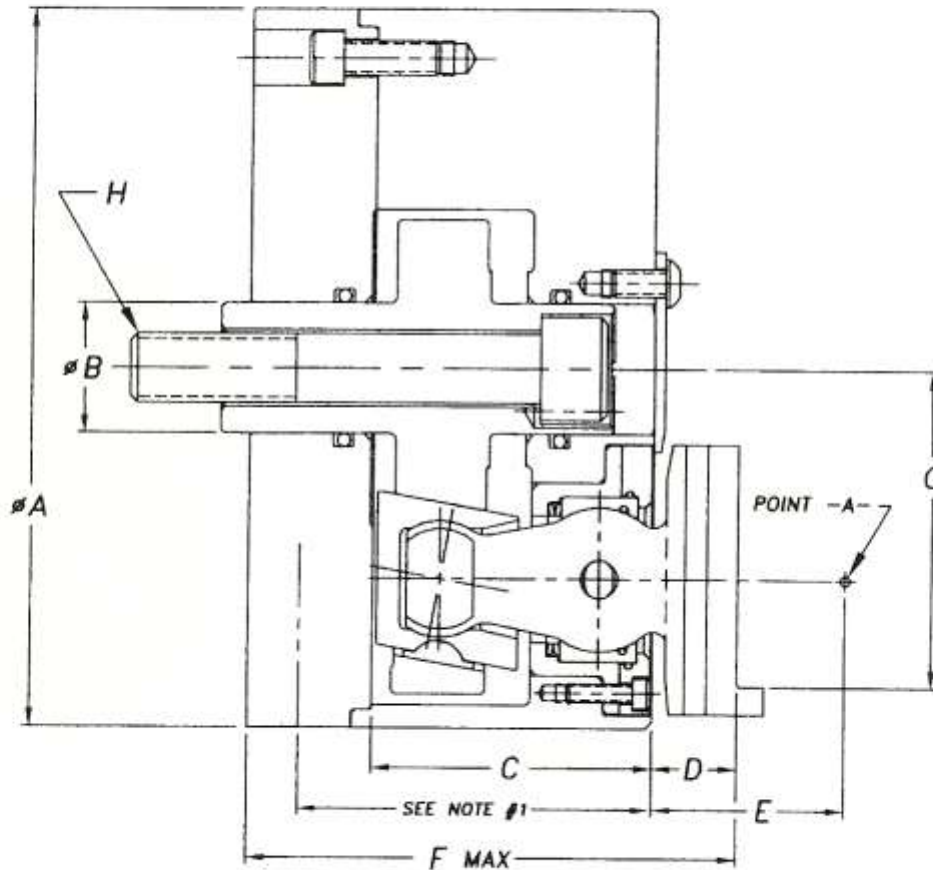

Optional Quick Change from External to Internal Chucking Mode Available

CHUCK SIZE	6"	8"	9"	10"	12"	15"	18"	21"	
THREE-JAW CENTRALIZING CHUCK ASSEMBLY	UBG 6000-W	UBG 8000-W	UBG 9000-W	UBG 10000-W	UBG 12000-W	UBG 15000-W	UBG 18000-W	UBG 21000-W	
DIMENSIONS	A	6.50	8.25	9.50	10.00	12.00	15.00	18.00	21.00
	B	1.18	1.25	1.50	1.50	1.50	2.25	3.50	3.50
	C	2.59	3.01	3.01	3.73	3.73	4.22	4.22	4.22
	D	.76	.93	.93	1.16	1.16	1.28	1.28	1.28
	E	1.83	2.08	2.08	2.61	2.61	2.94	2.94	2.94
	F	4.48	5.25	5.25	6.13	6.27	7.00	7.00	7.00
	G	2.875	3.500	4.250	4.437	5.250	6.750	8.250	9.750
H	5/8	5/8	5/8	5/8	5/8	1.00	1.00	1.00	
MAX. DRAWBAR IN LBS. OF FORCE	6,000	8,000	8,000	12,000	12,000	15,000	15,000	15,000	
TOTAL DRAWBAR TRAVEL - MINIMUM	.62	.68	.68	.88	.88	.88	1.12	1.12	
TOTAL JAW TRAVEL AT POINT -A- (DIAMETRICAL TRAVEL)	.28	.33	.33	.45	.45	.52	.52	.52	

*Note #1 MINIMUM CHUCK HEIGHT TO BE DETERMINED UPON RECEIPT OF MACHINE SPINDLE INFORMATION

- SHOWN ABOVE IS AN EXTERNAL GRIP CENTRALIZING CHUCK.
- MOST CHUCK SIZES ARE AVAILABLE AS STANDARD, IN EXTERNAL, INTERNAL, CENTRALIZING, COMPENSATING AND "CENTRALIZING-COMPENSATING".



ULTRA-GRIP

INTERNATIONAL

Your Engineered Workholding Solution

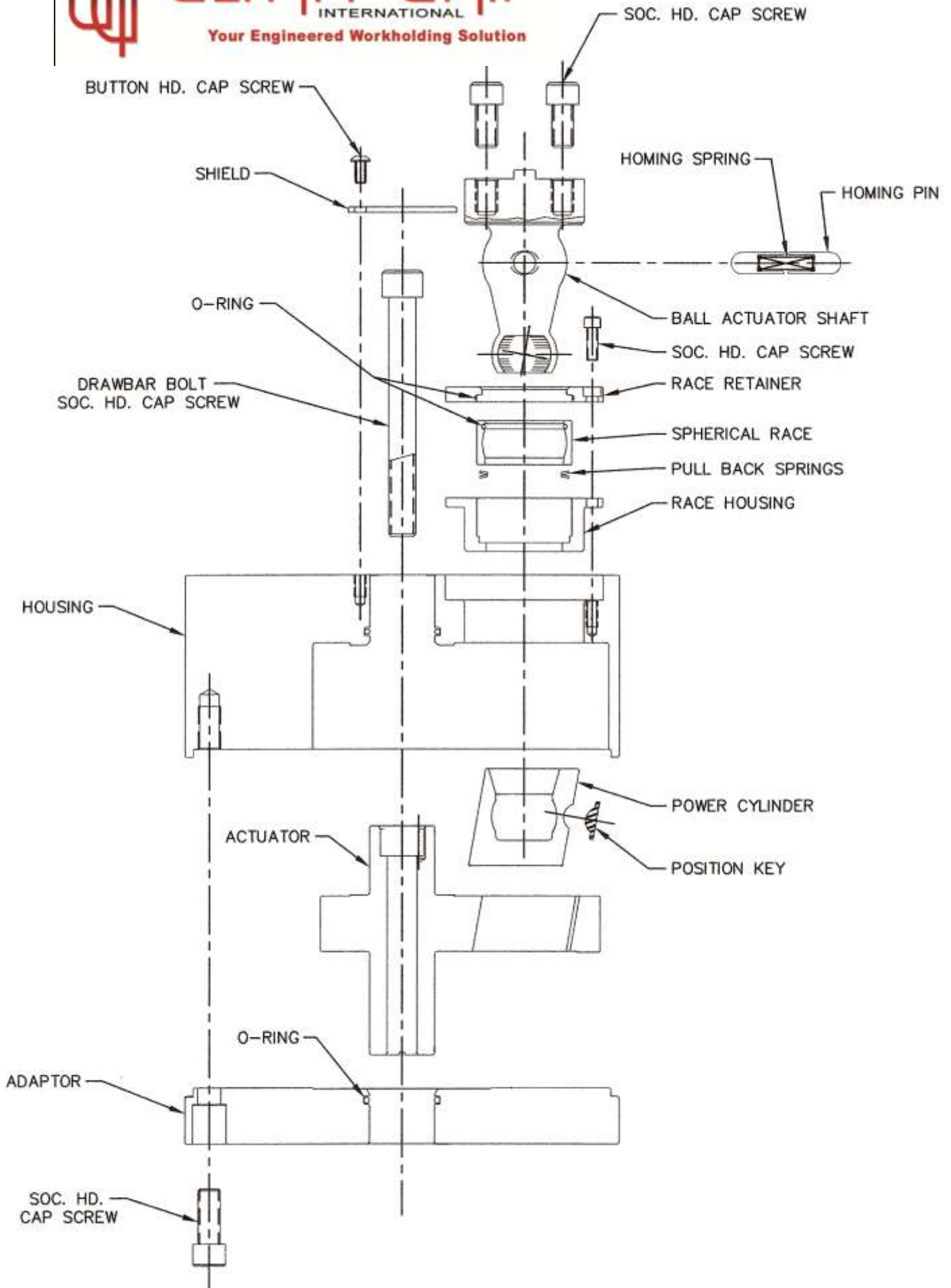



THREE POWER CHUCK DESIGNS—

[EXTERNAL/INTERNAL]

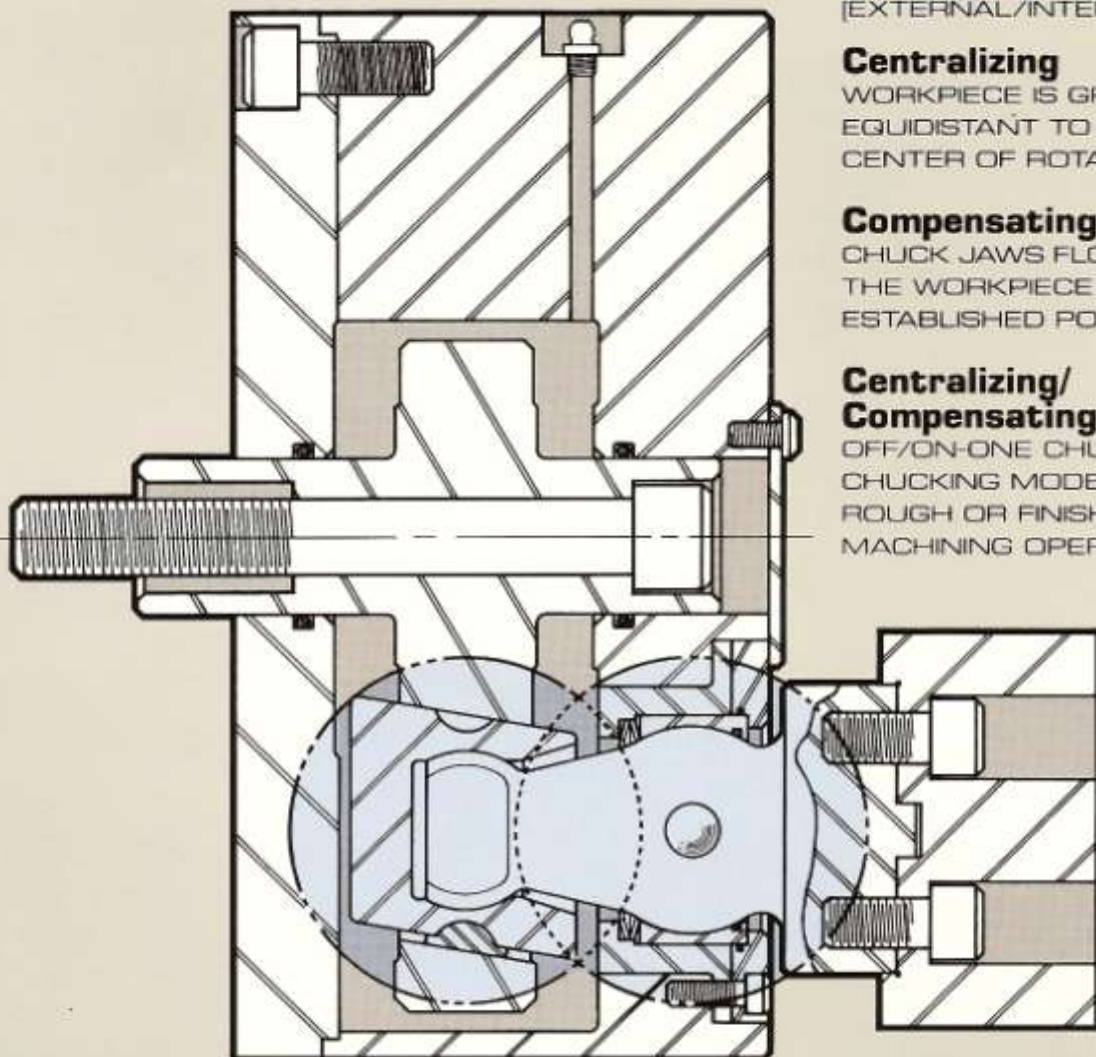

Centralizing

WORKPIECE IS GRIPPED EQUIDISTANT TO THE CENTER OF ROTATION

Compensating

CHUCK JAWS FLOAT TO GRIP THE WORKPIECE IN A PRE-ESTABLISHED POSITION

Centralizing/Compensating

OFF/ON-ONE CHUCK-TWO CHUCKING MODES FOR ROUGH OR FINISH MACHINING OPERATIONS

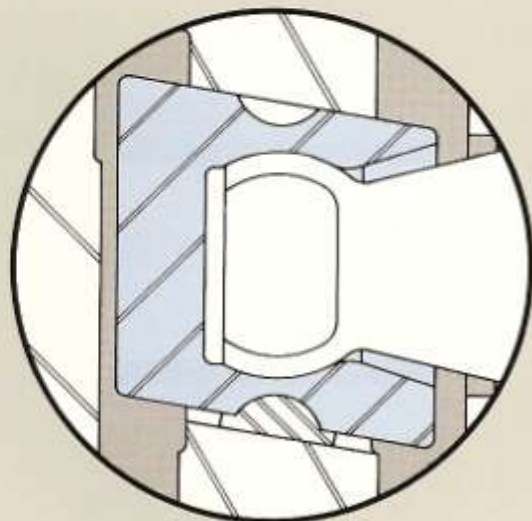

POWER CYLINDER GENERATES CONSTANT POWER RATIO— LESS INPUT—LESS WEAR

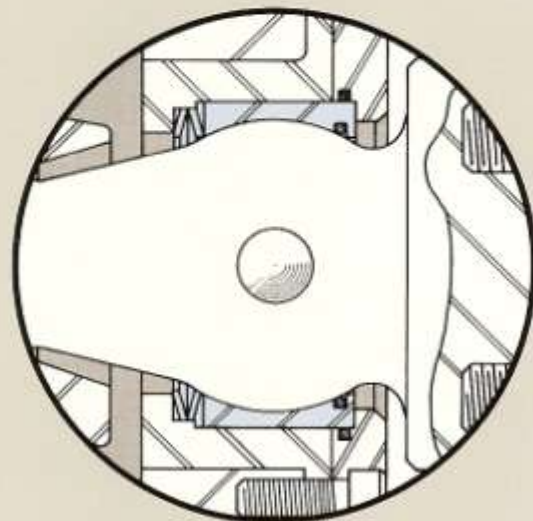

FULL CONTACT OF BALL ARM IN OUTER BEARING IMPROVES ACCURACY AND CHUCK SEAL

POWER CHUCK FEATURES

Ball Joint Construction

POWER MECHANISM OPERATES WITHIN A SEALED UNIT OF HIGH PRESSURE LUBRICANT.

High Power Ratio

HIGHER GRIPPING FORCE WITH LESS INPUT RESULTING IN LONGER CHUCK LIFE.

Jaw Travel

INCREASED JAW TRAVEL ENHANCES PART LOADING AND TOLERANCE VARIATIONS.

Sealed Design

ELIMINATES COSTLY MAINTENANCE AND DOWN TIME, INCREASING MACHINE TIME, PRODUCTIVITY AND PROFITS.

Pullback Action

STABILIZES PART AGAINST WORKSTOP PROVIDING POSITIVE LOCATION AND CONTROL OF CRITICAL MACHINING DIMENSIONS.

Jaw Swivel

COMPENSATES FOR PART VARIATION INSURING SIX POINT JAW CONTACT.

OTHER WORKHOLDING EQUIPMENT

- DIAPHRAGM CHUCKS
- ARBORS
- RETRACTABLE JAW CHUCKS
- PITCH-LINE GEAR CHUCKS
- POWER CHUCKS UP TO 60"
- THRU-HOLE CHUCKS
- PIN CHUCKS
- FACE CLAMP CHUCKS

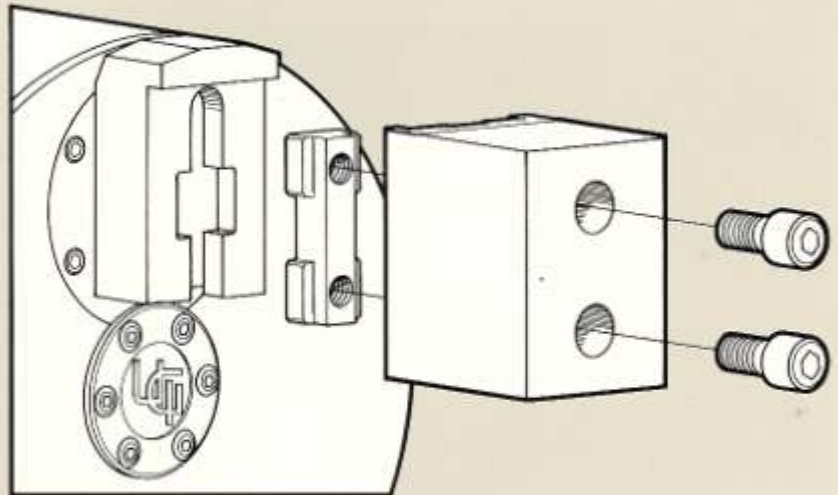

Quick Change Jaw Assembly

ELIMINATES SCREW REMOVAL — RAPIDLY CHANGE PART TOOLING

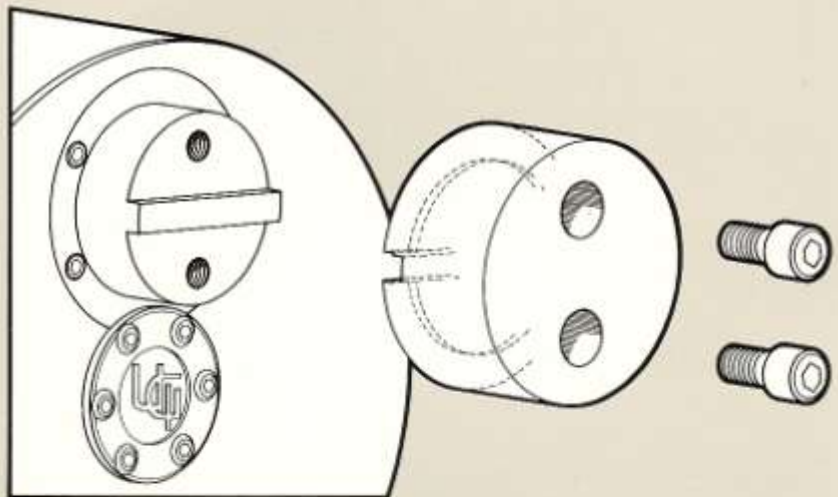

Single or Multiple Diameter Jaw

UTILIZE AS A SINGLE PURPOSE JAW OR AN INDEXABLE MULTIPLE DIAMETER JAW

REPLACEABLE JAW GRIPPERS

FULL SELECTION OF CARBIDE AND HARDENED GRIPPERS

ALL APPLICATIONS ARE ENGINEERED FOR
"THE ULTIMATE IN WORKHOLDING"

Replaceable Angular Inserts

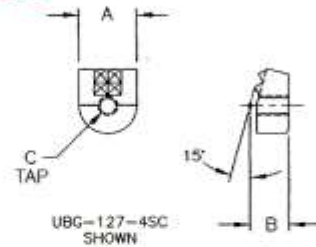
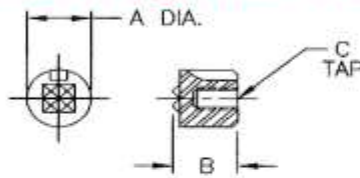
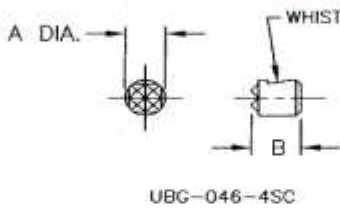

SOLID CARBIDE ROUND DESIGN

ULTRA-GRIP PART NO.	A	B	C	TOOTH PATTERN
UBG-046-4SC	5/16	3/8	N/A	4-POINT
UBG-070-4SC	1/2	1/2	#10-32	4-POINT
UBG-070-12SC	1/2	1/2	#10-32	12-POINT
UBG-071-4SC	5/8	5/8	1/4 - 28	4-POINT
UBG-071-20SC	5/8	5/8	1/4 - 28	20-POINT

ULTRA-GRIP REPLACEABLE INSERTS ELIMINATE COSTLY MAINTENANCE BY REDUCING CHUCK JAW INVENTORY AND INCREASING THE LIFE OF TOP JAWS. INSERTS CAN QUICKLY AND EASILY BE REPLACED REDUCING COSTLY DOWN TIME.

BOTH ANGULAR AND ROUND DESIGN STYLES MAKE POSSIBLE POSITIVE GRIPPING ON ROUGH OR SMOOTH SURFACES OF CASTINGS AND FORGINGS.

ADDITIONAL ADVANTAGES OF ANGULAR DESIGN: PROVIDE CLAMPING ON NARROW CHUCKING LANDS AND PERMIT GREATER TOOL CLEARANCE TOWARD TOP OF JAWS.

SOLID CARBIDE ANGULAR DESIGN

ULTRA-GRIP PART NO.	A	B	C	TOOTH PATTERN
UBG-127-4SCS	3/8	3/8	#10-32	4-POINT
UBG-127-4SCS-10MM	10 MM	3/8	M5 x 0.8P	4-POINT
UBG-127-4SCA	9/16	3/8	#10-32	2-POINT
UBG-127-4SC	9/16	3/8	#10-32	4-POINT
UBG-127-4SCM	9/16	3/8	M5 x 0.8P	4-POINT
UBG-127-10SC	9/16	3/8	#10-32	10-POINT
UBG-128-4SC	3/4	1/2	1/4-28	4-BLADE ANGULAR
UBG-130-2SCS	3/8	3/8	#10-32	2-BLADE STRAIGHT
UBG-130-4SC	9/16	3/8	#10-32	4-BLADE STRAIGHT
UBG-132-2SCS	3/8	3/8	#10-32	2-BLADE CROWNED
UBG-132-4SC	9/16	3/8	#10-32	4-BLADE CROWNED
UBG-145-5SC	9/16	3/8	#10-32	5-BLADE 45° ANGLE



4 Point



4 Point
Narrow



10 Point



4 Blade
Straight



4 Blade
Crowned



5 Blade
Angular





ULTRA-GRIP INTERNATIONAL

Your Engineered Workholding Solution

Counter Centrifugal Sliding Jaw Chuck

- ❑ Completely sealed low maintenance
- ❑ Reduced jaw force loss at high rpm's
- ❑ English and Metric serrations
- ❑ Constant gripping pressure
- ❑ Available through-coolant and/or air
- ❑ "T" slot locator block design
- ❑ Direct mounting for various spindles types
- ❑ .025 mm guaranteed repeatability with properly bored top jaws.

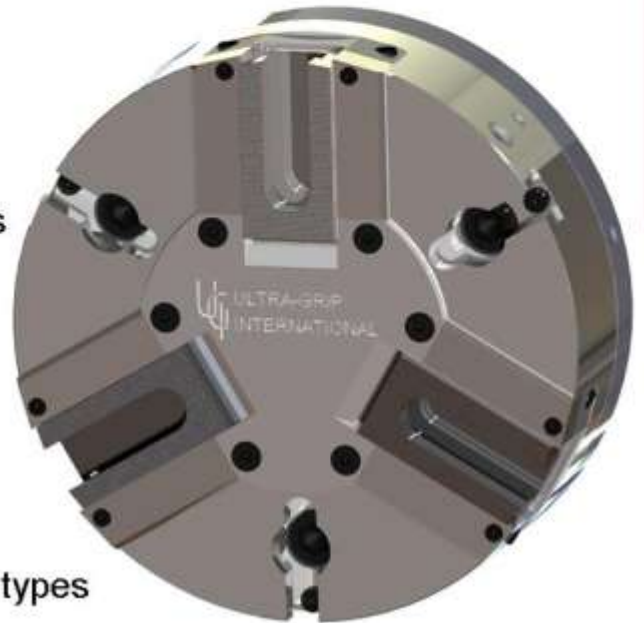

Power Chucks

Sliding Jaw Chuck Features

Counter Centrifugal

Centrifugal force is compensated by a sliding counter balance. This improves differential High-Low pressure chucking.

Jaw Travel

Increased jaw travel enhances part loading and tolerance variations.

Special designs

Ultra-Grip International offers special designs to suite your part requirements.

Design Interface

The Ultra-Grip Sliding Jaw Chuck directly interfaces with many competitor models.

English and Metric serrations

1/16" or 3/32" x 90 degree and 1.5mm x 60 degree serrations available.

Fully Sealed design

Ideal for dry machining of castings and forgings, or if high pressure coolant is used.

Standardized Components

We use common components wherever possible in our various sizes of our Sliding Jaw Chucks, reducing customer inventory requirements.

Engineering Expertise

Ultra-Grip International offers the assistance of our experienced engineering department in the design of all your workholding requirements.

Customer Assistance

Ultra-Grip's trained personnel provide immediate on-site customer service.



8155 Richardson Road Commerce Twp., Michigan 48390

248.363.0982 Fax 248.363.2057

Email: sales@ultra-grip.com Website: www.ultra-grip.com

Counter Centrifugal Sliding Jaw Chuck

- ❑ Reduced jaw force loss at high rpm's up to 5,700 rpm
- ❑ 3-Jaw Design
2-Jaw available upon request
- ❑ Large Thru-hole designs for Bar Feed applications
- ❑ .001 Guaranteed repeatability with properly bored top Jaws or Master Jaw Inserts
- ❑ Master Jaw Insert design
Use Master Jaw Inserts or top Jaws for gripping
- ❑ Available with standard A2 spindle mounting or special back plate designed for mounting to your specific machine spindle requirements.



Sliding Jaw Chuck Features

Master Slides

Master Slides come standard with American Standard square type serrations. Also available are American Tongue and Groove, Inch (1/16 x 90deg) and Metric (1.5mm x 60deg) "V" type serrations.

Jaw Travel

Increased jaw travel enhances part loading and tolerance variations. See Table for specifications.

Top Jaws

Blank top jaws available to suit Master Slides. Customer can insert a stress plug into the collet pad and turn blanks to suit specific part configurations. Special designed top jaws for roughing and finishing operations are also available upon request.

Design Interface

The Ultra-Grip SJC chuck directly interfaces with many competitors Sliding Jaw Chucks.

Counter Centrifugal

Centrifugal force is compensated by a one piece constructed counterbalance. This improves differential High-Low pressure chucking.

Customer Assistance

Ultra-Grip's trained personnel provide immediate on-site customer service.



Counter Centrifugal Sliding Jaw Chuck

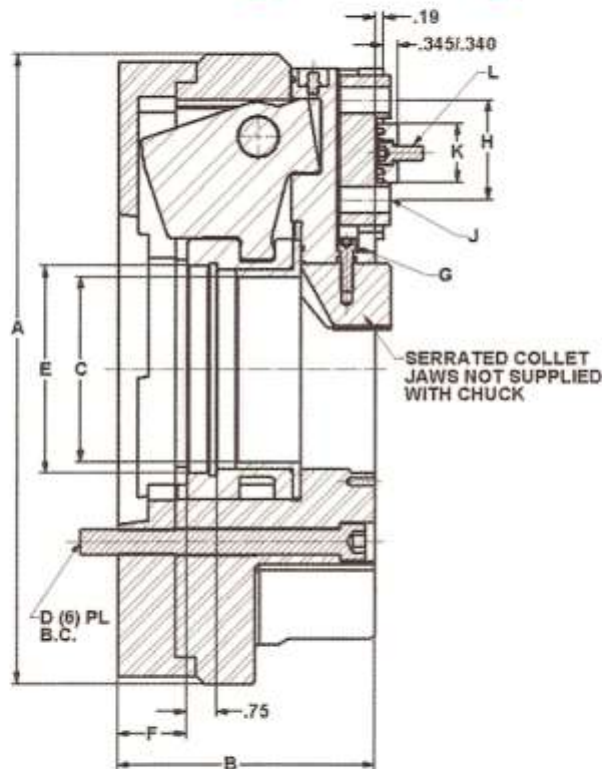

Model	SJC-9000	SJC-10000	SJC-13000	SJC-16000	SJC-18000
Size	8.75	10.00	12.75	15.75	18.00
Spindle nose	6A2	6A2	8A2	11A2	11A2
A Diameter	8.75	10.00	12.75	15.75	18.00
B Height	4.91	5.44	6.00	6.50	6.69
C Bore	2.06	2.75	3.38	4.81	4.81
D Bolt Circle	5.250	5.250	6.750	9.250	9.250
E Thread	2-3/4 x 12	3 1/8 x 12	4 1/8 x 12	5 1/4 x 12	5 1/4 x 12
F Max (open)/Min (closed)	1.47 / .94	1.56 / 1.09	1.56 / .81	1.78 / .87	1.96 / .84
G Diameter max	2.00	2.56	3.03	4.63	4.63
H Distance	1.44	1.75	1.75	2.50	2.50
J Thread	1/2-13	1/2-13	5/8-11	3/4-10	3/4-10
K Width	.745/.744	.995/.994	.995/.994	1.487/1.486	1.487/1.486
L Bolt size	1/4-20x3/4	5/16-18x3/4	5/16-18x3/4	3/8-16x3/4	3/8-16x3/4
Travel per jaw	.25	.28	.30	.40	.40
*Maximum RPM	5,700	4,200	3,700	3,200	2,700
Approx. weight (lbs)	60	90	127	190	285
*3-jaw max. drawbar force (lbf)	11,000	16,000	20,000	26,000	28,000
3-jaw static grip (lbf) per jaw	6,000	8,400	11,600	14,000	16,300
W/top jaws at max. drawbar force					
3-jaw static grip (lbf) per jaw	8,000	9,800	13,600	20,000	23,500
W/collet pads at max. drawbar force					

Note: Master slides are American Standard square serrations.

Each 3-jaw chuck is supplied with (3) jaw nuts, (3) master keys, (3) key screws, and (6) spindle screws.

* Operating RPM, drawbar force and top jaw configuration are contingent on each other. Consult Ultra-Grip engineering for appropriate top jaw weight.

Retractable jaw chucks



- Complete machining of shafts in one operation.
 - Improves part concentricity and endwise location.
 - Chuck jaws are extended to grip work piece for roughing.
 - Chuck jaws retracted for finish machining.
- Optional centers
 - Chuck can be provided with either a fixed center with power operated face driver or spring loaded center with face driver.

Retractable Jaw Driver Chuck

- ❑ Chuck allows for complete machining of shaft between centers in only one set-up improving part concentricity and endwise location. Work piece is clamped between centers and driven by the face driver to qualify clamping diameter. Chuck jaws are extended to grip work piece providing additional gripping force for rough machining operation. Chuck jaws are retracted and work piece is driven by face driver for finish machining operation.
- ❑ Chuck can be provided with either a fixed center with power operated face driver or spring loaded center with fixed face driver.

Complete Workholding Package

- ❑ Ultra-Grip can provide cylinder assembly, spindle adapter, drawbar and drawtube.



Retractable Jaw Driver Chuck Features

Compensating Chuck

Chuck design enables jaws to grip work piece independent of chuck center.

Sealed Design

Eliminates costly maintenance and down time, increase productivity and profits.

Accuracy

Guaranteed repeatability within .001" TIR.

Higher Speeds

Machining speeds up to 4,500 rpm depending on chuck size.

Positive End Driving

Face driving pins compensate to an out-of-square part end face ensuring equal distribution of driving force.

Customer Assistance

Ultra-Grip's trained personnel provide immediate on site customer service.

Supported Pivot Point

Extend or retract jaws while rotating, jaw arms remain supported while extended minimizing centrifugal jaw force loss.

Ball Joint Construction

Power mechanism operates within a sealed unit of lubricant.

8155 Richardson Road Walled Lake, Michigan 48390 248.363.0982 Fax 248.363.4949

e-mail: sales@ultra-grip.com Website: www.ultra-grip.com



Manufactured & Assembled in the USA

RETRACTABLE JAW DRIVER CHUCK

SOLID CENTER WITH
POWERED DRIVER BLADES

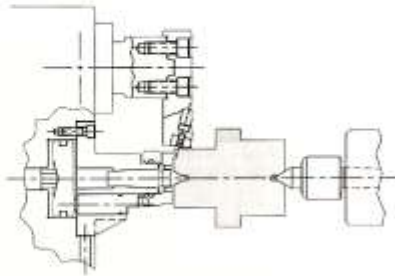

* DUAL PISTON CYLINDER REQUIRED

SPRING LOADED CENTER WITH
FIXED DRIVER BLADES

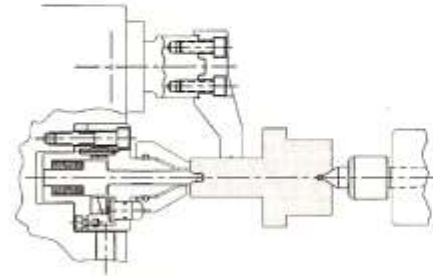

* SINGLE PISTON CYLINDER REQUIRED

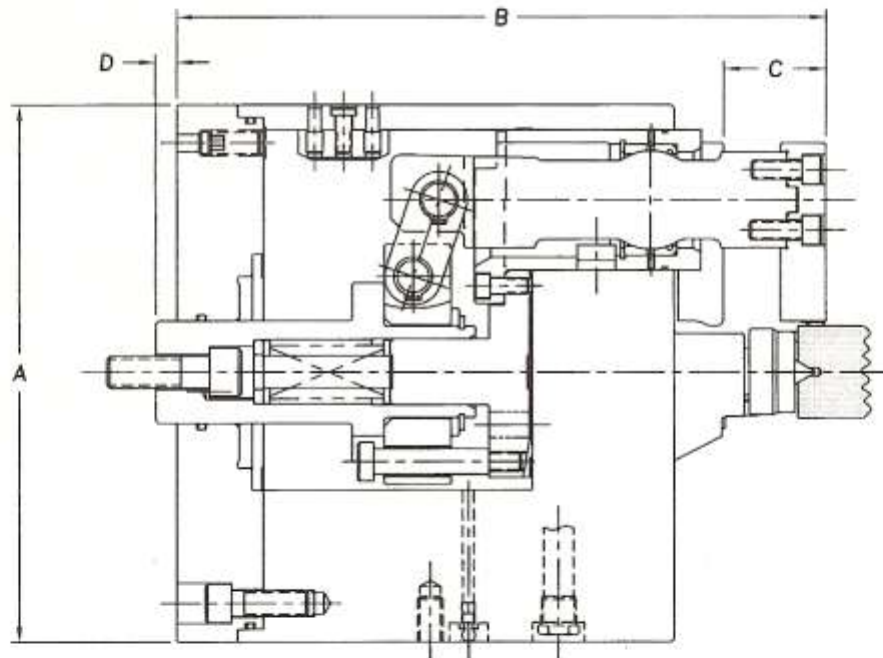

DIMENSIONS	A	B	C	D	TOTAL JAW OPENING ON DIA	MAXIMUM DRAWBAR PULL (LBS)	PART DIAMETER RANGE
PART NUMBER	OUTSIDE DIAMETER	OVERALL LENGTH	STANDARD JAW RETRACTION	STANDARD ACTUATOR TRAVEL			
RDC-8000	8.25	10.15	1.50	1.94	.200	6,000	.62 - 3.25
RDC-10000	10.25	12.78	2.00	2.47	.250	8,000	1.50 - 4.25
RDC-12000	12.25	12.78	2.00	2.47	.250	8,000	2.00 - 6.00
RDC-15000	15.00	12.89	2.00	2.47	.250	12,500	4.00 - 7.50

- MINIMUM CHUCK HEIGHT TO BE DETERMINED UPON RECEIPT OF MACHINE SPINDLE INFORMATION
- OTHER CHUCK SIZES AVAILABLE
- STROKE DETECTION RECOMMENDED

Ultra-Lock Collet Arbors

Ultra-Lock Collet Arbors Are Available in a Variety of Designs

- Flange mounted style drawbar actuated.
- Between centers style wrench actuated.
- Flange style with air cylinder assembly.

Collet Arbor Features

- Components are standardized permitting interchangeability and off-the-shelf delivery.
- Different size collets are interchangeable within a given arbor size.
- Guaranteed .0005" TIR repeatability when checking directly over chucking lands with a cylindrical master test piece.
- Provides versatility with easy changing of collets.



Additional Ultra-Lock Collet Arbor Features

Ultra-Lock Design

Precision inclined flats on arbor body, expander and collet

Greater Torque

Drive transmitted through mating flats eliminating the need for keying collet to arbor body

Accuracy

Preload feature ensures flats remain in constant contact from part load through entire clamping range of collet

Power Advantage

Operating pressures increased through inclined flats

Long Life

Built-in safety stops provide positive control of both collet expansion and contraction

Design Feature

Collet compensates to locate a tapered or straight bore on center

Collet Sealing

Sealing of collet slots is available on request at extra cost.

Self-Releasing

Collets are manufactured to include preload which ensures fast, easy part removal

Customer Assistance

Ultra-Grip's trained personnel provide immediate customer service

Custom Design

Ultra-Lock feature can be incorporated in special design applications

Pullback Action

Ensures part seating against work stop and squaring-up on locating face providing positive location and control of critical machining dimensions

Ultra-Lock Flange Style Drawbar-Actuated Arbors

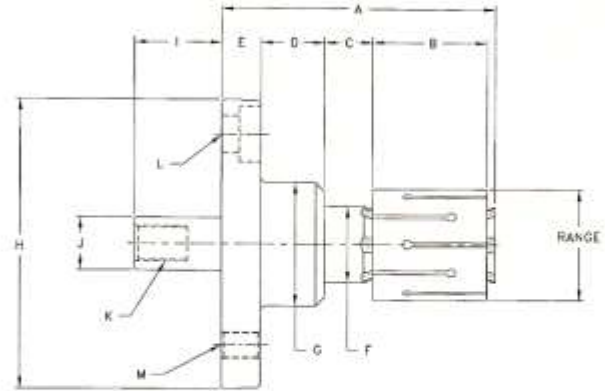

Long Series

Catalog No.	Range	A	B	C	D	E	F	G	H	I	J	K	L	M
ULC-2110	<u>500 - 655</u> 10 Collets	2.49	.88	.39	.66	.50	<u>.4702</u> .4692	1.25	<u>3.3755</u> 3.3750	.750	.562	3/8 - 24	For (4) 3/8 S.H.S. on 2.50 B.C.	(4)5/16 - 24 on 2.50 B.C.
ULC-2210	<u>593 - 780</u> 12 Collets	2.69	1.06	.41	.66	.50	<u>.5798</u> .5786	1.25	<u>3.3755</u> 3.3750	.750	.562	3/8 - 24	For (4) 3/8 S.H.S. on 2.50 B.C.	(4)5/16 - 24 on 2.50 B.C.
ULC-2310	<u>718 - 999</u> 18 Collets	2.96	1.25	.49	.66	.50	<u>.7046</u> .7036	1.25	<u>3.3755</u> 3.3750	.750	.562	3/8 - 24	For (4) 3/8 S.H.S. on 2.50 B.C.	(4)5/16 - 24 on 2.50 B.C.
ULC-2410	<u>875 - 1.397</u> 17 Collets	3.58	1.44	.56	.90	.56	<u>.8452</u> .8442	1.75	<u>4.1255</u> 4.1250	1.220	.750	1/2 - 20	For (4) 1/2 S.H.S. on 3.12 B.C.	(4) 3/8 - 24 on 2.875
ULC-2510	<u>1.125 - 1.656</u> 17 Collets	3.89	1.62	.69	.90	.56	<u>1.0796</u> 1.0786	1.75	<u>4.1255</u> 4.1250	1.220	.750	1/2 - 20	For (4) 1/2 S.H.S. on 3.12 B.C.	(4) 3/8 - 24 on 2.875
ULC-2610	<u>1.468 - 2.092</u> 20 Collets	4.14	1.81	.82	.72	.68	<u>1.4077</u> 1.4067	2.50	<u>4.8755</u> 4.8750	1.590	.968	3/4 - 16	For (4) 1/2 S.H.S. on 3.75 B.C.	(4)3/8 - 24 on 3.625 B.C.
ULC-2710	<u>1.937 - 2.843</u> 29 Collets	4.46	2.00	1.00	.66	.68	<u>1.8452</u> 1.8442	2.50	<u>4.8755</u> 4.8750	1.590	.968	3/4 - 16	For (4) 1/2 S.H.S. on 3.75 B.C.	(4)3/8 - 24 on 3.625 B.C.
ULC-2810	<u>2.562 - 3.593</u> 33 Collets	4.83	2.25	1.12	.66	.68	<u>2.4390</u> 2.4385	3.00	<u>5.5005</u> 5.5000	1.590	.968	3/4 - 16	For (4) 1/2 S.H.S. on 4.50 B.C.	(4)3/8 - 24 on 3.625 B.C.
ULC-2910	<u>3.312 - 4.467</u> 37 Collets	4.97	2.50	1.11	.56	.68	<u>3.1855</u> 3.1880	3.62	<u>5.5005</u> 5.5000	1.590	.968	3/4 - 16	For (4) 1/2 S.H.S. on 4.50 B.C.	(4)3/8 - 24 on 3.625 B.C.

Components

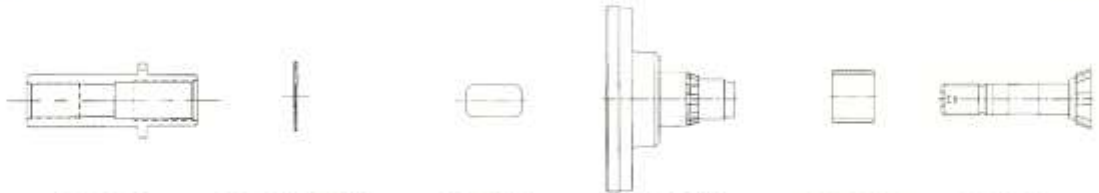

FOR USE ON	CONNECTOR CATALOG NO.	RETAINING RING CATALOG NO.	LOCK PIN CATALOG NO.	ARBOR BODY CATALOG NO.	DIRT SEAL CATALOG NO.	EXPANDER CATALOG NO.
ULC-2110	ULC-162-A	ULC-8186	ULC-8185	ULC-159	ULC-190	ULC-165
ULC-2210	ULC-162-A	ULC-8186	ULC-8185	ULC-259	ULC-291	ULC-265
ULC-2310	ULC-362-A	ULC-8186	ULC-8185	ULC-359	ULC-391	ULC-365
ULC-2410	ULC-462-A	ULC-8486	ULC-8485	ULC-459	ULC-491	ULC-465
ULC-2510	ULC-562-A	ULC-8486	ULC-8485	ULC-559	ULC-591	ULC-565
ULC-2610	ULC-662-A	ULC-8686	ULC-8685	ULC-659	ULC-691	ULC-665
ULC-2710	ULC-662-A	ULC-8686	ULC-8685	ULC-759	ULC-791	ULC-765
ULC-2810	ULC-862-A	ULC-8686	ULC-8685	ULC-859	ULC-890	ULC-865
ULC-2910	ULC-862-A	ULC-8686	ULC-8685	ULC-959	ULC-990	ULC-965

Ultra-Lock Flange Style Drawbar-Actuated Arbors

ULTRA-GRIP
INTERNATIONAL, INC.
the ultimate in workholding

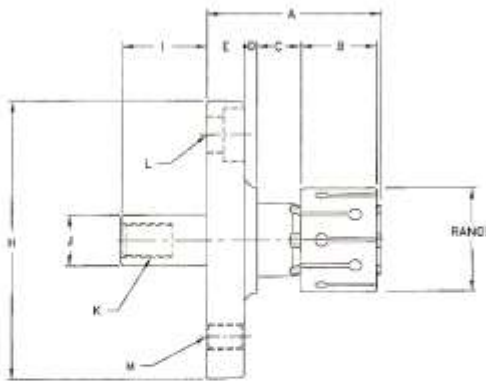

Short Series

Catalog No.	Range	A	B	C	D	E	F	G	H	I	J	K	L	M
ULC-8100	.500 - .655 15 Collets	1.81	.59	.42	.25	.50	.4702 .4692	.88	3.3755 3.3750	.781	.562	3/8 - 24	For (4) 3/8 S.H.S. on 2.50 B.C.	(4) 5/16 - 24 on 2.375 B.C
ULC-8200	.593 - .797 20 Collets	1.97	.72	.45	.25	.50	.5796 .5786	1.00	3.3755 3.3750	.781	.562	3/8 - 24	For (4) 3/8 S.H.S. on 2.50 B.C.	(4) 5/16 - 24 on 2.375 B.C
ULC-8300	.718 - 1.000 28 Collets	2.15	.84	.51	.25	.50	.7046 .7036	1.12	3.3755 3.3750	.781	.562	3/8 - 24	For (4) 3/8 S.H.S. on 2.50 B.C	(4) 5/16 - 24 on 2.375 B.C
ULC-8400	.875 - 1.299 20 Collets	2.35	.94	.59	.18	.56	.8452 .8442	1.38	4.1255 4.1250	1.250	.750	1/2 - 20	For (4) 1/2 S.H.S. on 3.12 B.C.	(4) 3/8 - 24 on 2.875 B.C.
ULC-8500	1.125 - 1.624 24 Collets	2.59	1.12	.65	.18	.56	1.0796 1.0786	1.56	4.1255 4.1250	1.250	.750	1/2 - 20	For (4) 1/2 S.H.S. on 3.12 B.C.	(4) 3/8 24 on 2.875 B.C
ULC-8600	1.468 - 2.104 30 Collets	2.93	1.22	.83	.12	.68	1.4077 1.4076	1.88	4.8755 4.8750	1.625	.968	3/4 - 16	For (4) 1/2 S.H.S. on 3.75 B.C.	(4) 3/8 24 on 3.625 B.C
ULC-8700	1.937 - 2.821 42 Collets	2.98	1.31	.79	.12	.68	1.8452 1.8442	2.38	4.8755 4.8750	1.625	.968	3/4 - 16	For (4) 1/2 S.H.S. on 3.75 B.C	(4) 3/8 - 24 on 3.625 B.C.

Components

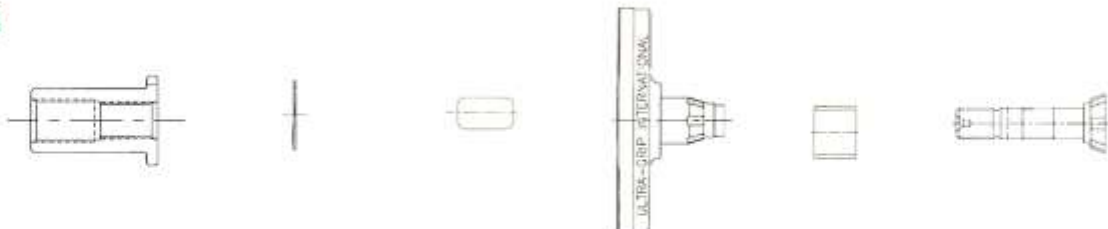

FOR USE ON	CONNECTOR CATALOG NO.	RETAINING RING CATALOG NO.	LOCK PIN CATALOG NO.	ARBOR BODY CATALOG NO.	DIRT SEAL CATALOG NO.	EXPANDER CATALOG NO.
ULC-8100	ULC-8262	ULC-8186	ULC-8185	ULC-8152	ULC-8190	ULC-8165
ULC-8200	ULC-8262	ULC-8186	ULC-8185	ULC-8252	ULC-8290	ULC-8265
ULC-8300	ULC-8362	ULC-8186	ULC-8185	ULC-8352	ULC-8390	ULC-8365
ULC-8400	ULC-8462	ULC-8486	ULC-8485	ULC-8452	ULC-8490	ULC-8465
ULC-8500	ULC-8562	ULC-8486	ULC-8485	ULC-8552	ULC-8590	ULC-8565
ULC-8600	ULC-8662	ULC-8686	ULC-8685	ULC-8652	ULC-8690	ULC-8665
ULC-8700	ULC-8662	ULC-8686	ULC-8685	ULC-8752	ULC-8790	ULC-8765



Manufactured & Assembled in the USA

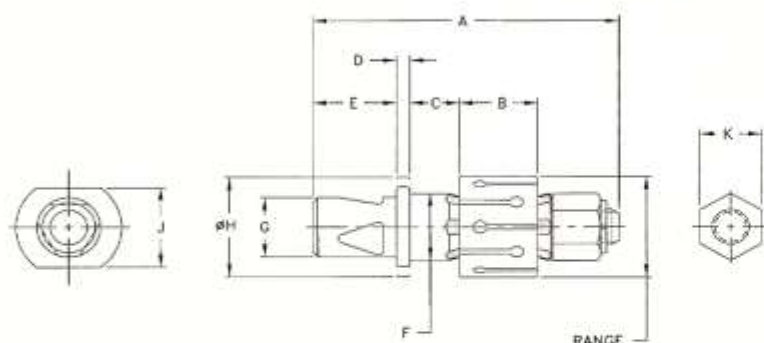

Long Series

Catalog No.	Range	A	B	C	D	E	F	G	H	J	K
ULC-1100	<u>.500 - .655</u> 10 Collets	2.49	.88	.39	.12	.75	<u>.4702</u> .4692	<u>.5005</u> .4995	.82	.68	.44
ULC-1200	<u>.593 - .780</u> 12 Collets	2.90	1.06	.42	.12	.75	<u>.5796</u> .5786	<u>.5005</u> .4995	.88	.75	.44
ULC-1300	<u>.718 - .999</u> 18 Collets	3.18	1.25	.50	.12	.75	<u>.7046</u> .7036	<u>.5005</u> .4995	1.00	.88	.56
ULC-1400	<u>.875 - 1.397</u> 17 Collets	3.96	1.44	.56	.16	1.00	<u>.8452</u> .8442	<u>.7505</u> .7495	1.25	1.00	.75
ULC-1500	<u>1.125 - 1.656</u> 17 Collets	4.46	1.62	.68	.18	1.00	<u>1.0796</u> 1.0786	<u>.7505</u> .7495	1.50	1.25	.88
ULC-1600	<u>1.468 - 2.092</u> 20 Collets	5.25	1.82	.82	.22	1.25	<u>1.4077</u> 1.4067	<u>1.0005</u> .9995	1.88	1.62	1.12
ULC-1700	<u>1.937 - 2.843</u> 29 Collets	5.82	2.00	1.00	.25	1.25	<u>1.8452</u> 1.8442	<u>1.0005</u> .9995	2.38	2.06	1.38
ULC-1800	<u>2.562 - 3.593</u> 33 Collets	7.06	2.25	1.10	.31	1.88	<u>2.4390</u> 2.4380	<u>1.6255</u> 1.6245	2.88	2.62	2.00
ULC-1900	<u>3.312 - 4.467</u> 37 Collets	7.31	2.50	1.10	.31	1.88	<u>3.1890</u> 3.1880	<u>1.6255</u> 1.6245	3.75	3.38	2.00

Short Series

Catalog No.	Range	A	B	C	D	E	F	G	H	J	K
ULC-7100-A	<u>.500 - .655</u> 15 Collets	2.52	.59	.40	.12	.75	<u>.4702</u> .4692	<u>.5005</u> .4995	.82	.68	.44
ULC-7200-A	<u>.593 - .797</u> 20 Collets	2.66	.72	.44	.12	.75	<u>.5796</u> .5786	<u>.5005</u> .4995	.88	.75	.44
ULC-7300-A	<u>.718 - 1.000</u> 28 Collets	2.91	.84	.52	.12	.75	<u>.7046</u> .7036	<u>.5005</u> .4995	1.00	.88	.56
ULC-7400-A	<u>.875 - 1.299</u> 20 Collets	3.56	.94	.56	.16	1.00	<u>.8452</u> .8442	<u>.7505</u> .7495	1.25	1.00	.75
ULC-7500-A	<u>1.125 - 1.624</u> 24 Collets	3.97	1.125	.68	.18	1.00	<u>1.0796</u> 1.0786	<u>.7505</u> .7495	1.50	1.25	.88
ULC-7600-A	<u>1.468 - 2.104</u> 30 Collets	4.81	1.22	.81	.22	1.25	<u>1.4077</u> 1.4067	<u>1.0005</u> .9995	1.88	1.62	1.12
ULC-7700-A	<u>1.937 - 2.821</u> 42 Collets	5.25	1.31	1.00	.25	1.25	<u>1.8452</u> 1.8442	<u>1.0005</u> .9995	2.38	2.06	1.38

Air Cylinder Assembly for Ultra-Lock Flange-Style Arbors

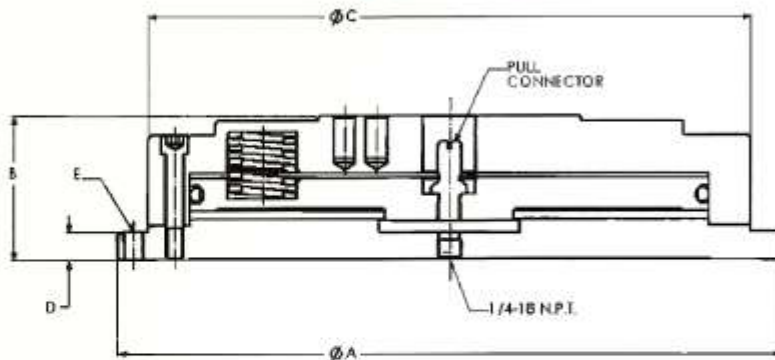

CYLINDER ASM CATALOG NO.	A	B	C	D	E	PULL CONNECTOR CATALOG NO.	FOR USE WITH ULTRA-LOCK FLANGE STYLE ARBORS
ULC-3007	8.19	2.91	6.88	.72	(6) .406 HOLES ON 7.50 B.C.	ULC-135 ULC-136	ULC-2110, 2210, 2310, 8100, 8200, 8300 ULC-2410, 2510, 8400, 8500
ULC-3010	11.19	3.03	9.88	.72	(6) .406 HOLES ON 10.50 B.C.	ULC-137 ULC-138 ULC-139	ULC-2110, 2210, 2310, 8100, 8200, 8300 ULC-2410, 2510, 8400, 8500 ULC-2610, 2710, 8600, 8700
ULC-3013	14.19	3.09	6.88	.72	(6) .406 HOLES ON 13.50 B.C.	ULC-138 ULC-139	ULC-2410, 2510, 8400, 8500 ULC-2610, 2710, 2810, 2910, 8600, 8700

- Ultra-Grip Air Cylinder Assemblies are designed for spring grip-air release. Recommend using 70 P.S.I. operating pressure to obtain optimal clamping force at set-up.
- Standard Air Cylinder Assembly is furnished with a face plate style flanged mounted adaptor plate. Ultra-Grip can provide a custom adaptor plate to mount directly to customer's machine spindle.

Ultra-Lock Arbor Work Stop Recommendations

Ultra-lock Arbors have "pull-back" action, therefore all applications require a work stop.

- Fixed Work Stop is recommended for part pieces where the endwise locating surface is square to locating diameter.
- Rocker Style Work Stop is recommended for part pieces where the endwise locating surface is not square to locating diameter.
- Restrictor Style Work Stop is a combination Work Stop and Retaining Sleeve and is required for a part piece where the locating length of the part is shorter than the collet. The Ultra-Lock Collet expands from both ends, therefore a retaining sleeve is necessary to prevent the free end of the collet from over expanding. A Restrictor Expander is required to reduce the expansion safety stop to prevent collet breakage if the arbor is operated without a part piece in place.

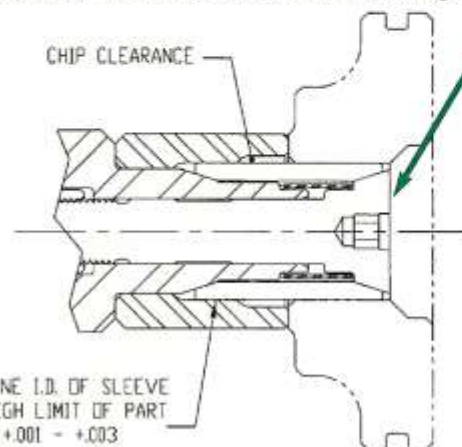

RESTRICTOR EXPANDER Catalog No.	
Long	Short
ULC-167	ULC-8167
ULC-267	ULC-8267
ULC-367	ULC-8367
ULC-467	ULC-8467
ULC-567	ULC-8567
ULC-667	ULC-8667
ULC-767	ULC-8767
ULC-867	
ULC-967	



Manufactured & Assembled in the USA



Ultra-Lock Collets

- Collets ULC-107 thru 110, ULC-209 thru 212, ULC-311 thru 318 and ULC-413 thru 417 should be used only for light turning or grinding operations.
- Accuracy of arbor not affected by indexing of collet on arbor body.
- High-alloy special steel heat treated to provide maximum service life.
- Precision machined flats provides long-term accuracy and torque transmission.

Long Series

For use on ULC-1100 & ULC-2110 Arbors

RANGE	COLLET NO.
.500-.515	ULC-101
.516-.530	102
.531-.546	103
.547-.561	104
.562-.577	105
.578-.592	106
.593-.608	107
.609-.623	108
.624-.639	109
.640-.655	110

Length
.89

For use on ULC-1200 & ULC-2210 Arbors

RANGE	COLLET NO.
.593-.608	ULC-201
.609-.624	202
.625-.639	203
.640-.655	204
.656-.670	205
.671-.686	206
.687-.702	207
.703-.717	208
.718-.733	209
.734-.749	210
.750-.764	211
.765-.780	212

Length
1.06

For use on ULC-1300 & ULC-2310 Arbors

RANGE	COLLET NO.
.718-.733	ULC-301
.734-.749	302
.750-.764	303
.765-.780	304
.781-.796	305
.797-.812	306
.813-.827	307
.828-.843	308
.844-.858	309
.859-.874	310
.875-.890	311
.891-.905	312
.906-.921	313
.922-.936	314
.937-.952	315
.953-.967	316
.968-.983	317
.984-.999	318

Length
1.25

For use on ULC-1400 & ULC-2410 Arbors

RANGE	COLLET NO.
.875-.905	ULC-401
.906-.936	402
.937-.967	403
.968-.999	404
1.000-1.030	405
1.031-1.061	406
1.062-1.092	407
1.093-1.124	408
1.125-1.155	409
1.156-1.186	410
1.187-1.217	411
1.218-1.249	412
1.243-1.273	413
1.274-1.304	414
1.305-1.335	415
1.336-1.366	416
1.367-1.397	417

Length
1.44

For use on ULC-1500 & ULC-2510 Arbors

RANGE	COLLET NO.
1.125-1.155	ULC-501
1.156-1.186	502
1.187-1.217	503
1.218-1.249	504
1.250-1.280	505
1.281-1.311	506
1.312-1.342	507
1.343-1.374	508
1.375-1.405	509
1.406-1.436	510
1.437-1.467	511
1.468-1.499	512
1.500-1.530	513
1.531-1.561	514
1.562-1.592	515
1.593-1.624	516
1.625-1.656	517

Length
1.62

For use on ULC-1600 & ULC-2610 Arbors

RANGE	COLLET NO.
1.468-1.499	ULC-601
1.500-1.530	602
1.531-1.561	603
1.562-1.592	604
1.593-1.624	605
1.625-1.655	606
1.656-1.686	607
1.687-1.717	608
1.718-1.749	609
1.750-1.780	610
1.781-1.811	611
1.812-1.842	612
1.843-1.874	613
1.875-1.905	614
1.906-1.936	615
1.937-1.967	616
1.968-1.999	617
2.000-2.030	618
2.031-2.061	619
2.062-2.092	620

Length
1.82

For use on ULC-1700 & ULC-2710 Arbors

RANGE	COLLET NO.
1.937-1.967	ULC-701
1.968-1.999	702
2.000-2.030	703
2.031-2.061	704
2.062-2.092	705
2.093-2.124	706
2.125-2.155	707
2.156-2.186	708
2.187-2.217	709
2.218-2.249	710
2.250-2.280	711
2.281-2.311	712
2.312-2.342	713
2.343-2.374	714
2.375-2.405	715
2.406-2.436	716
2.437-2.467	717
2.468-2.499	718
2.500-2.530	719
2.531-2.562	720
2.563-2.593	721
2.594-2.624	722
2.625-2.655	723
2.656-2.686	724
2.687-2.718	725
2.719-2.749	726
2.750-2.780	727
2.781-2.811	728
2.812-2.843	729

Length
2.00

For use on ULC-1800 & ULC-2810 Arbors

RANGE	COLLET NO.
2.562-2.593	ULC-801
2.594-2.624	802
2.625-2.655	803
2.656-2.686	804
2.687-2.718	805
2.719-2.749	806
2.750-2.780	807
2.781-2.811	808
2.812-2.843	809
2.844-2.874	810
2.875-2.905	811
2.906-2.936	812
2.937-2.968	813
2.969-2.999	814
3.000-3.030	815
3.031-3.061	816
3.062-3.093	817
3.094-3.124	818
3.125-3.155	819
3.156-3.186	820
3.187-3.218	821
3.219-3.249	822
3.250-2.280	823
3.281-3.311	824
3.312-3.343	825
3.344-3.374	826
3.375-3.405	827
3.406-3.436	828
3.437-3.468	829
3.469-3.499	830
3.500-3.530	831
3.531-3.561	832
3.562-3.593	833

Length
2.25

For use on ULC-1900 & ULC-2910 Arbors

RANGE	COLLET NO.
3.312-3.343	ULC-901
3.344-3.374	902
3.375-3.405	903
3.406-3.436	904
3.437-3.468	905
3.469-3.499	906
3.500-3.530	907
3.531-3.561	908
3.562-3.593	909
3.594-3.624	910
3.625-3.655	911
3.656-3.686	912
3.687-3.718	913
3.719-3.749	914
3.750-3.780	915
3.781-3.811	916
3.812-3.843	917
3.844-3.874	918
3.875-3.905	919
3.906-3.936	920
3.937-3.968	921
3.969-3.999	922
4.000-4.030	923
4.031-4.061	924
4.062-4.093	925
4.094-4.124	926
4.125-4.155	927
4.156-4.186	928
4.187-4.217	929
4.218-4.249	930
4.250-4.280	931
4.281-4.311	932
4.312-4.342	933
4.343-4.374	934
4.375-4.405	935
4.406-4.436	936
4.437-4.467	937

Length
2.50



Ultra-Lock Arbor & Collet Installation Instructions

- For all styles of Ultra-Lock Arbors the collet expansion safety stop is fixed and no adjustment is required. The collet contraction safety stop is adjustable and must be set to allow for loading of part piece.
- All collets are manufactured with expansion preload. Corresponding flats on collets and arbor must be in contact during installation adjustment.
- Collets should not be adjusted below the minimum size specified for a collet range. Collet preloads are approximately .008" on .500 through .874 diameter collets and approximately .015" on .875 through 4.467 diameter collets.

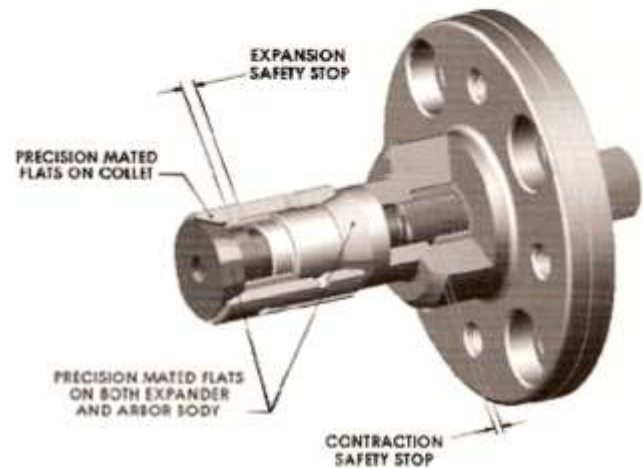

Collet and Arbor Assembly Installation

- **Ultra-Lock Flange Style Drawbar Actuated Arbor Collet Change-over**
With drawbar in full forward position remove expander with hex key wrench. Remove collet and dirt seal sleeve. Clean arbor components and lightly grease expander flats & shaft, and collet flats. Replace dirt seal sleeve and position collet into place with flats in contact. Install expander and adjust with hex key wrench until a low limit part piece is a slip fit on the collet. Flats on both ends of the collets must mate.
- **Ultra-Lock Air-Operated Flange Style Arbor Collet Installation**
With air pressure at 70 P.S.I. remove expander with hex key wrench. Remove collet and dirt seal sleeve. Clean arbor components and lightly grease expander flats & shaft, and collet flats. Replace dirt seal sleeve and position collet into place with flats in contact. Install expander and adjust with hex key wrench until a low limit part piece is slip fit on the collet. Flats on both ends of the collet must mate.
Arbor Installation
Remove Arbor mounting screws. Apply 70 P.S.I. air pressure allowing piston to move forward and turn arbor assembly counterclockwise until drawbar disengages from piston assembly. Mount new Arbor assembly by turning arbor assembly clockwise until face contacts cylinder; then back off to align tapped holes in cylinder. Insert mounting screws until snug, release air pressure and tighten mounting screws.
- **Ultra-Lock Between Centers Style Arbor Collet Change-Over**
Remove lock-nut, expander nut and expander sleeve. Remove collet and dirt seal sleeve. Clean arbor components and lightly grease expander flats, collet flats and arbor shaft. Replace dirt seal sleeve and position collet into place with flats in contact. Install expander; assemble expander nut and lock-nut. Expand collet by turning expansion nut until a low limit part piece is a slip fit on the collet, flats on both ends of the collets must mate. Turn lock-nut with wrench until snug against operating nut.

Recommended Drawbar Pressures

The following chart is only a general rule-of-thumb guide, actual drawbar pressure is to be determined by customer. In any case do not exceed the maximum pounds listed, this is the maximum force the arbor is rated to withstand. Excessive drawbar pressure can break expander shaft, and insufficient drawbar pressure will allow the part to slip on the collet.

Ultra-Lock Flange Style Drawbar Actuated Arbor				Light Turning Light Grinding or Inspection Minimum LBS	Medium Turning Medium Grinding Minimum LBS	Heavy Turning Heavy Grinding Maximum LBS
Long Series		Short Series				
Catalog No	Catalog No	Range	Range			
ULC - 2110	.500 - .655	ULC - 8100	.500 - .655	1,000	1,500	2,000
ULC - 2210	.593 - .780	ULC - 8200	.593 - .797	1,000	1,500	2,000
ULC - 2310	.718 - .999	ULC - 8300	.718 - 1.000	1,300	2,500	3,100
ULC - 2410	.875 - 1.397	ULC - 8400	.875 - 1.299	2,000	4,500	6,700
ULC - 2510	1.125 - 1.656	ULC - 8500	1.125 - 1.642	2,500	6,000	11,500
ULC - 2610	1.468 - 2.092	ULC - 8600	1.468 - 2.104	3,000	10,000	23,000
ULC - 2710	1.937 - 2.843	ULC - 8700	1.937 - 2.821	3,000	11,000	23,000
ULC - 2810	2.562 - 3.593	-	-	3,500	12,000	23,000
ULC - 2910	3.312 - 4.467	-	-	3,500	13,000	23,000

8155 Richardson Road Walled Lake, Michigan 48390 248.363.0982 Fax 248.363.4949
e-mail: sales@ultra-grip.com Web site: www.ultra-grip.com

Collet chucks



- High accuracy
 - .0005 repeatability
- Multiple operations
 - I.D. and O.D.
- Master collet
 - Replaceable collet inserts for quick part changeover.
- Static and Pull down
 - Pulls part down securely against part stop.

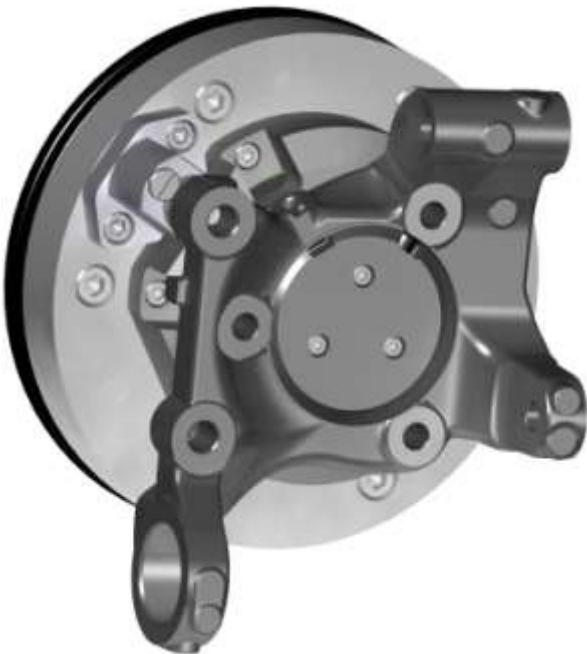

Face Clamping Chucks



Four clamp system

- Positive pull down against part stop.
- Multiple centralizing applications
 - Collet
 - Center
 - Pins

Diaphragm chucks

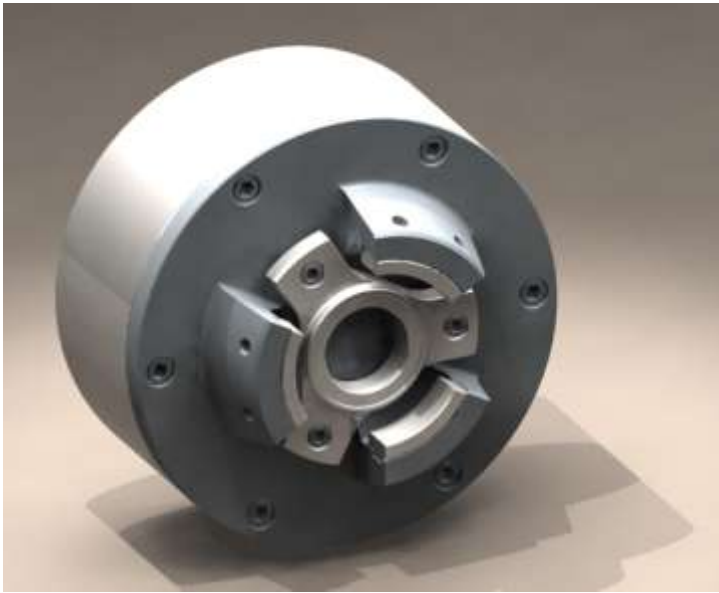

- Precision
 - Repeatability of .0002.
- Actuation
 - Single acting (diaphragm clamp)
 - Double acting drawbar “push-pull”
- High r.p.m.
 - Counterweighted jaws allow for increased r.p.m..
- One piece construction
- Pitch line gear chucking
 - Syncro pin guides part into gripping pins.
 - Roll pin cage systems.
 - Part load “on the fly”

Quick change systems



- Reduced setup time
 - From several hours to several minutes.
- High accuracy
 - .0002 repeatability
- Multiple chucking applications
 - Use any type of chuck with the sender plate
- Quick change top jaws
 - Using the same principle we can quick change top jaws also.

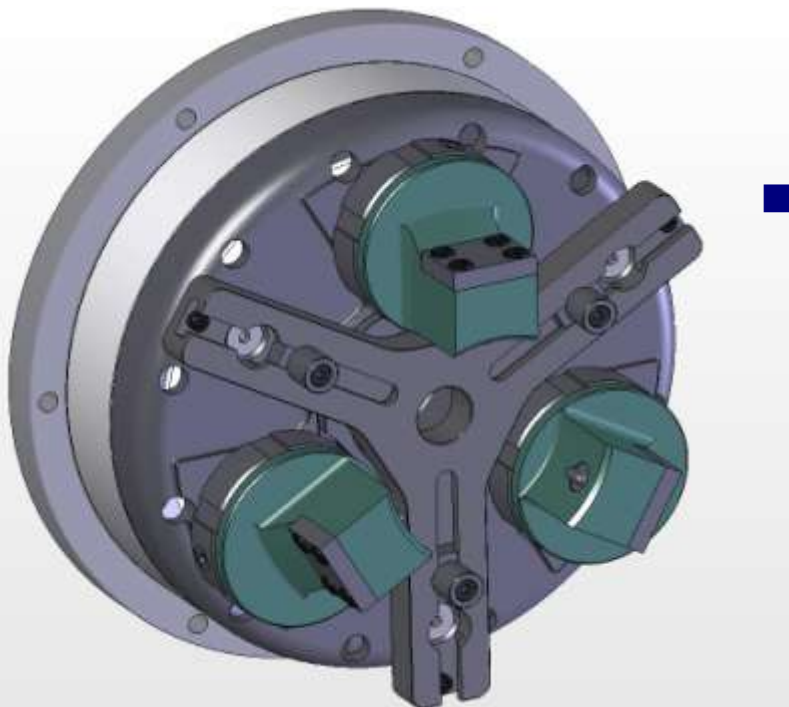



ULTRA-GRIP

INTERNATIONAL

Your Engineered Workholding Solution

Power Chucks

Quick Change Power Chucks

- ❑ Jaw change over in seconds
- ❑ Individual locking device for each jaw
- ❑ Safety lock wrench design
- ❑ Large through hole
- ❑ Hardened chuck body
- ❑ Mounts to various spindles types
- ❑ Interchangeable top jaw design
- ❑ Reversible jaw design
- ❑ Special sizes available upon request

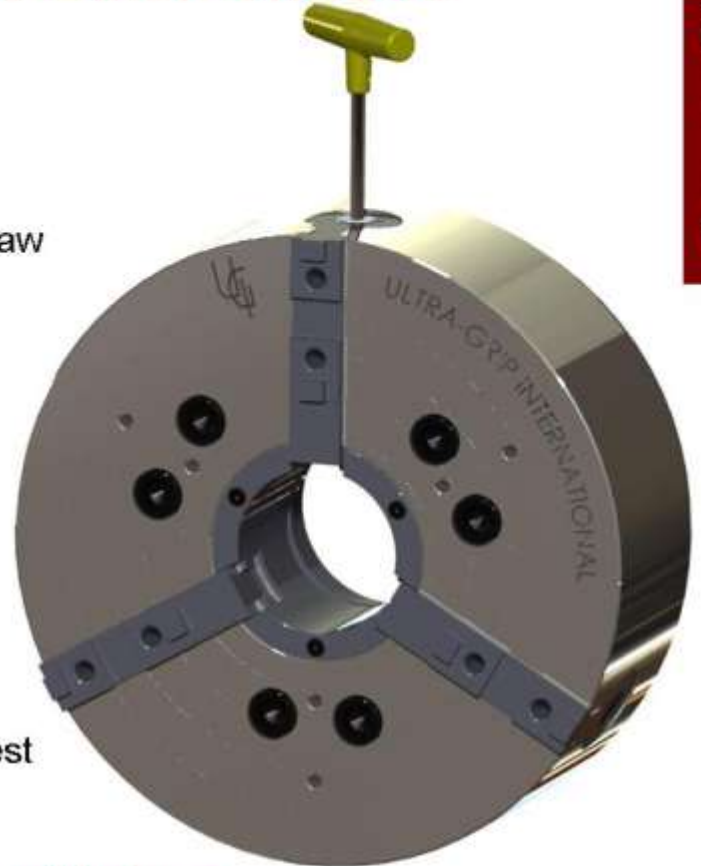

Quick Change Power Chuck additional features

Hardened chuck body

Chuck body is heat treated to assure longer life and greater accuracy.

Individual locking device for each jaw.

Each jaw has a separate locking device to assure accuracy and safety.

Special designs

Ultra-Grip International offers special designs to suite your part requirements.

Jaw design

Available in tongue and groove master jaws, one piece stepped master jaws, soft mono block and special designed jaws.

Reversible jaw design

Go from ID to OD by simply removing the jaw and rotating it back into the chuck.

Safety Lock wrench design

Wrench can not be removed until locking system is engaged properly.

Standardized Components

We use common components wherever possible in our various sizes of our Quick Change Power Chucks, reducing customer inventory requirements.

Engineering Expertise

Ultra-Grip International offers the assistance of our experienced engineering department in the design of all your workholding requirements.

Customer Assistance

Ultra-Grip's trained personnel provide immediate on-site customer service.



8155 Richardson Road Commerce Twp., Michigan 48390

248.363.0982 Fax 248.363.2057

Email: sales@ultra-grip.com Website: www.ultra-grip.com



ULTRA-GRIP

INTERNATIONAL

Your Engineered Workholding Solution

New Product !!!

ERGOGRIP

System
Patent Pending



High Precision Quick change, that doesn't break your back or your bank account.

Ultra-Grip International, a supplier of precision work holding products, announces a new addition to its quick change arsenal, the precision Ergo-Grip System. This quick change ergonomically designed jaw system is the little brother of Ultra-Grips QC (Quick Change) chuck system.

The Ergo-Grip system uses the same high precision gear coupling but in a much smaller package. This ensures the same high precision (.0002/5microns repeatability) in a lighter more ergonomically correct package. The precision ground gear tooth eliminates any boring or re-indication of the jaws after changeover. In a matter of seconds, by simply turning the retention coupling, the jaws can be removed and replaced with jaws for a different part size. You can change from gripping a simple ground surface to a complex pitch line gear chucking application utilizing the same chuck without re-indication. This saves thousands of dollars in man hours and capital equipment expenditures.

The retention coupling securely locks the jaws into position via a high pressure angle thread. This high pressure angle is used in conjunction with the precision ground tooth form to provide a positive and accurate locking mechanism.

The Ergo-Grip systems works for both I.D. and O.D. rotating and stationary applications. Counter Centrifugal designs are available for higher rpm's. Sensitive gripping pressures can be achieved eliminating part deformation. This is very useful in thin-walled part applications.

Completely sealed from any contaminants, this maintenance free system is the solution for your quick change needs.

Ultra-Grip International
8155 Richardson Road
Commerce Twp., MI 48390
www.ultra-grip.com
Phone: 248-363-0982



Loosen retention coupling



Remove jaws



Install jaw and tighten



ULTRA-GRIP

INTERNATIONAL

Your Engineered Workholding Solution

Quick Change Diaphragm Chucks

- ❑ Reduced changeover times by rotating the coupling and removing top jaws.
- ❑ Guaranteed .0002 repeatability
- ❑ Positive gripper pin reduces costly set up time.
- ❑ Ideal for grinding and hard turning applications.
- ❑ Work piece clamping on the O.D. or the pitch line.
- ❑ Self-Cleaning gear tooth coupling ensures accuracy and low maintenance.

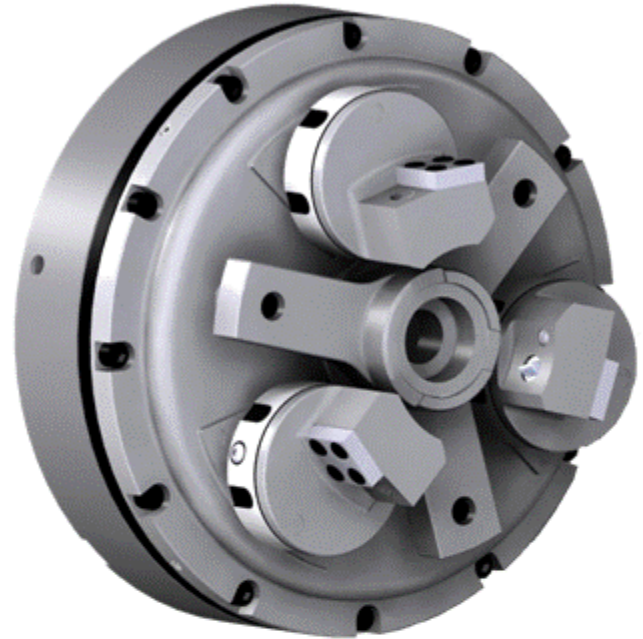

Precision Chucks

Quick Change Diaphragm Additional Features

Sealed Design

Eliminates costly maintenance and down time, increasing machine time, productivity and profits.

Easy Mounting

Mounts to all popular machine spindles. With the self contained option can also be mounted to a milling plate or tombstone fixture.

Actuation Systems

Diaphragm clamp or drawbar operated push/pull unclamping clamping methods.

Quick Change Top Jaw

Top jaws can be engineered to suit virtually any application. Just send in your part drawing and our engineers will design to suit.

High Grade Material

Our precision diaphragm chucks are designed with the highest grade of materials to assure repeatability and accuracy.

Centrifugal compensation

Counter weighted top jaws reduce centrifugal force loss at higher rpm's.

Standardized Components

We use common components wherever possible in our various sizes of Quick Change Diaphragm chucks, reducing customer inventory requirements.

Engineering Expertise

Ultra-Grip International offers the assistance of our experienced engineering department in the design of all your work holding requirements.

Customer Assistance

Ultra-Grip's trained personnel provide immediate on-site customer service.



8155 Richardson Road Commerce Twp., Michigan 48390
248.363.0982 Fax 248.363.2057
Email: sales@ultra-grip.com Website: www.ultra-grip.com



ULTRA-GRIP
INTERNATIONAL
the ultimate in workholding

DISCOVER THE ULTIMATE IN
**QUICK CHANGE
WORKHOLDING SYSTEMS**

GUARANTEED REPEATABILITY WITHIN .0002 T.I.R.



SELF CLEANING HARDEN AND GROUND TEETH

THREADED RETENTION RING (ROTATE 35° TO LOCK SENDER PLATE TO RECEIVER)

RECEIVER PLATE

SENDER PLATES WITH PROTECTED AND SELF CLEANING HARDENED AND GROUND TEETH

WORK HOLDING SENDER PLATE #1

WORK HOLDING SENDER PLATE #2



I.D. CHUCKING

RECEIVER PLATE

THREADED
RETENTION RING

CUSTOMER PART
TO BE MACHINED

SENDER PLATE #1



O.D. CHUCKING



ULTRA-GRIP ROTATING OR STATIONARY APPLICATIONS

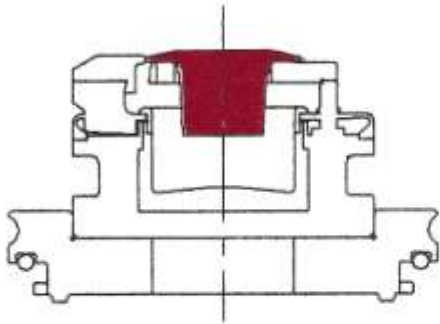

O.D. DIAPHRAGM CHUCK
With Quick Change Inserts

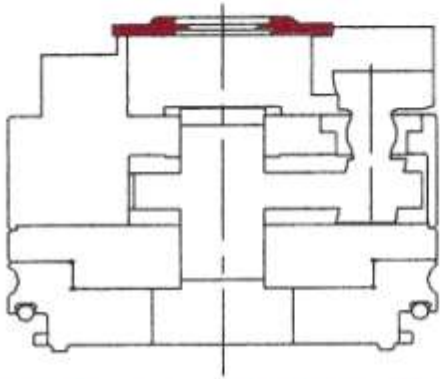

O.D. UBG POWER CHUCK

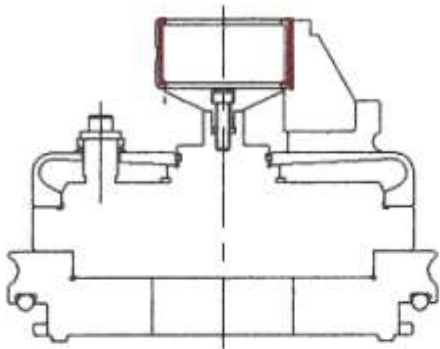

O.D. DIAPHRAGM CHUCK

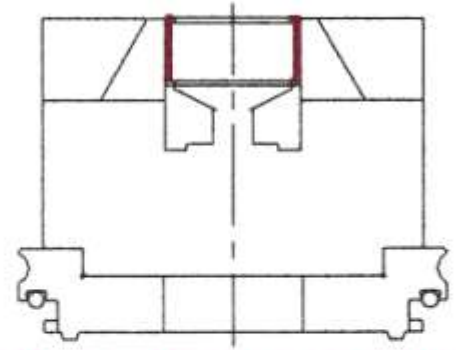

O.D. or I.D. COLLET CHUCK

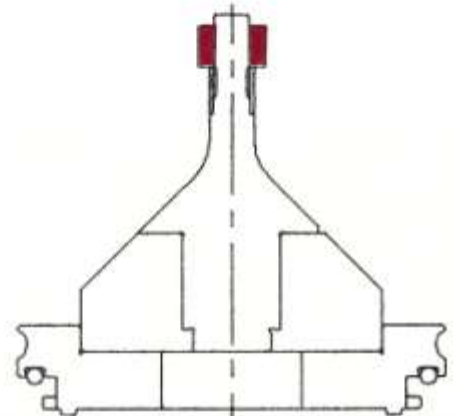

SINGLE TAPER HOBGING ARBOR

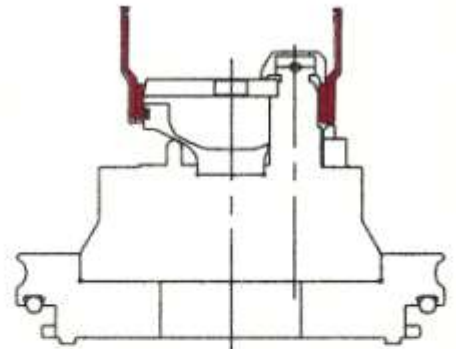

TWIST FINGER CHUCK
(Face Clamping)

THE ULTIMATE

SELF CLEANING
PRECISION GROUND TEETH

SPINDLE FACE
OR TABLE
(TO SUIT)

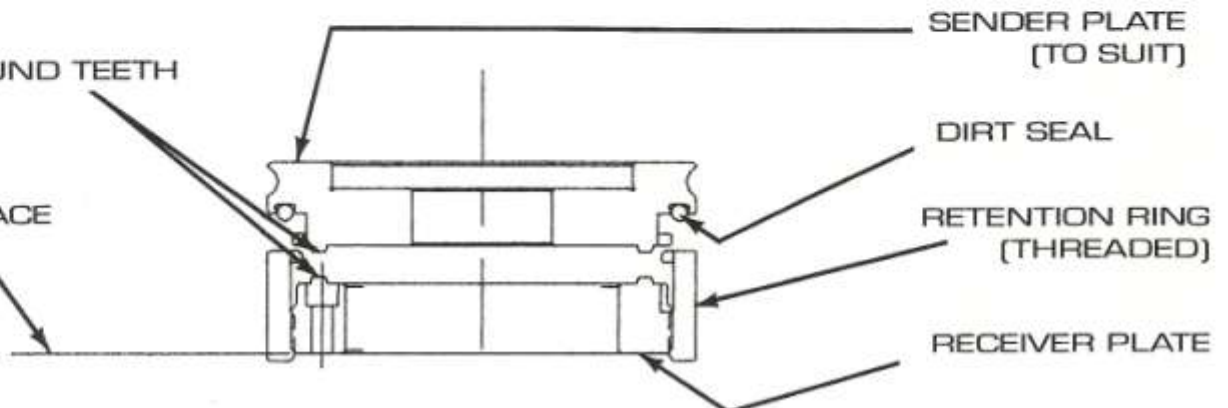

SENDER PLATE
(TO SUIT)

DIRT SEAL

RETENTION RING
(THREADED)

RECEIVER PLATE

PALLET APPLICATION – FIXTURES

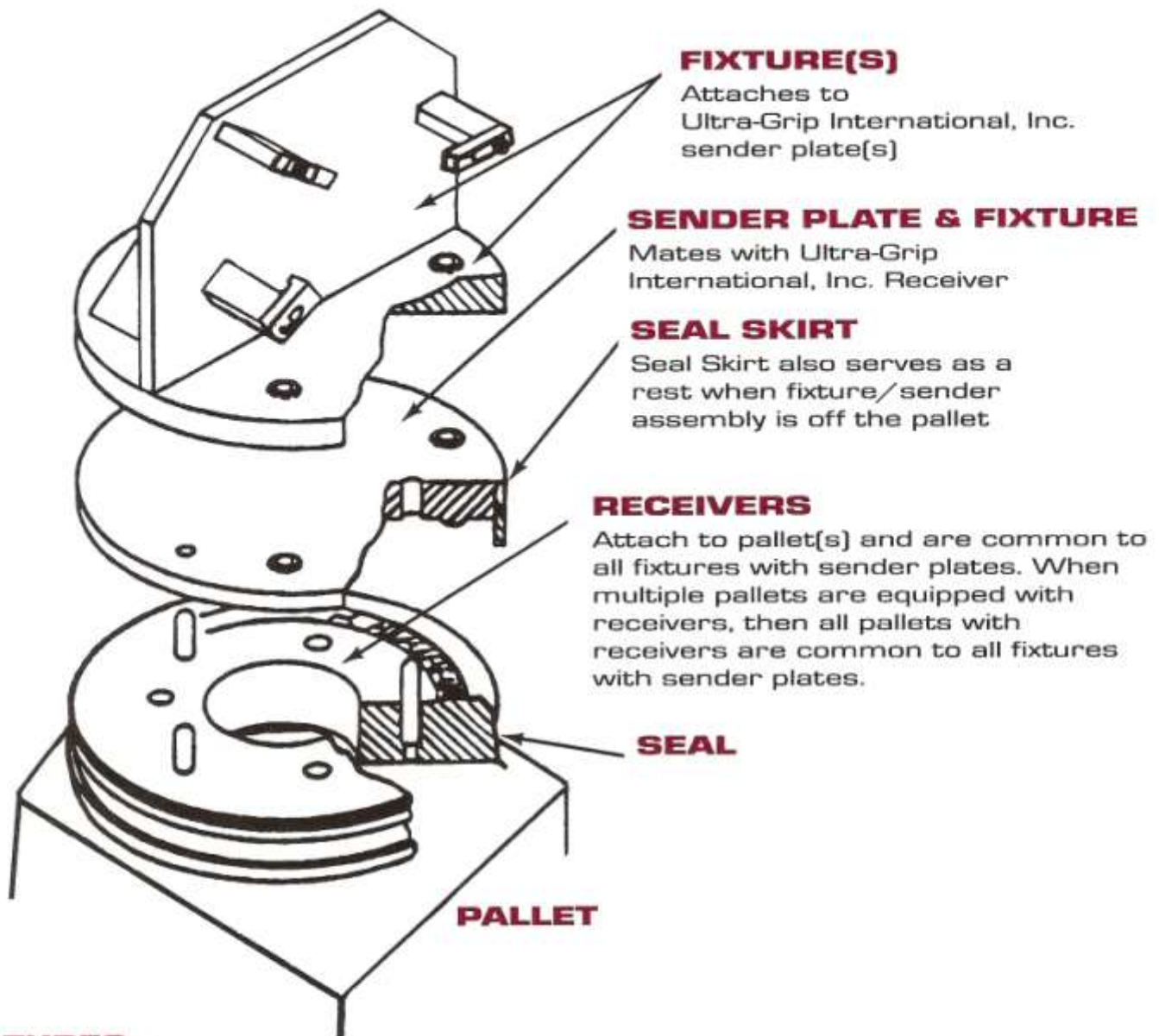

FEATURES:

- A.** Receiver and sender plates with hardened and ground self cleaning teeth.
- B.** Receiver and sender plates sealed from outside contamination.
- C.** Threaded ring retention to securely lock sender plates to receiver.
- D.** Receiver and sender plates sizes from 4.00" outside dia. to 72.00" outside dia..
- E.** Can be used for O.D. and I.D. chucking.
- F.** Can be used for rotating or stationary applications.
- G.** Bolt down, face clamp and automatic retention knob systems available.

BENEFITS:

- A.** Repeatability of .0002 (eliminates need to re-indicate at set-up).
- B.** Sender plate change over in less than (2) min.
- C.** Very low profile.
- D.** Allows for maintenance of workholding fixture to be performed off the machine.
- E.** Can use existing workholding by adapting sender plate to back of fixture.
- F.** Can reduce set-up time from (4) hrs. to (2) min.
- G.** Allows for off-line set-up to increase machine productivity.
- H.** The Ultra-Grip International, Inc. Quick-Change Workholding System is a two-part system, allowing any one of many chucks or fixtures to be used in conjunction with one receiver. This enables the user to reduce machine set-up time and/or the number of machines to efficiently produce different products.

Hobbing and Shaving Arbors



- Accuracy
 - .0002 repeatability
- Rigid design
 - Solid body design
- Standard replacements for most major brands.

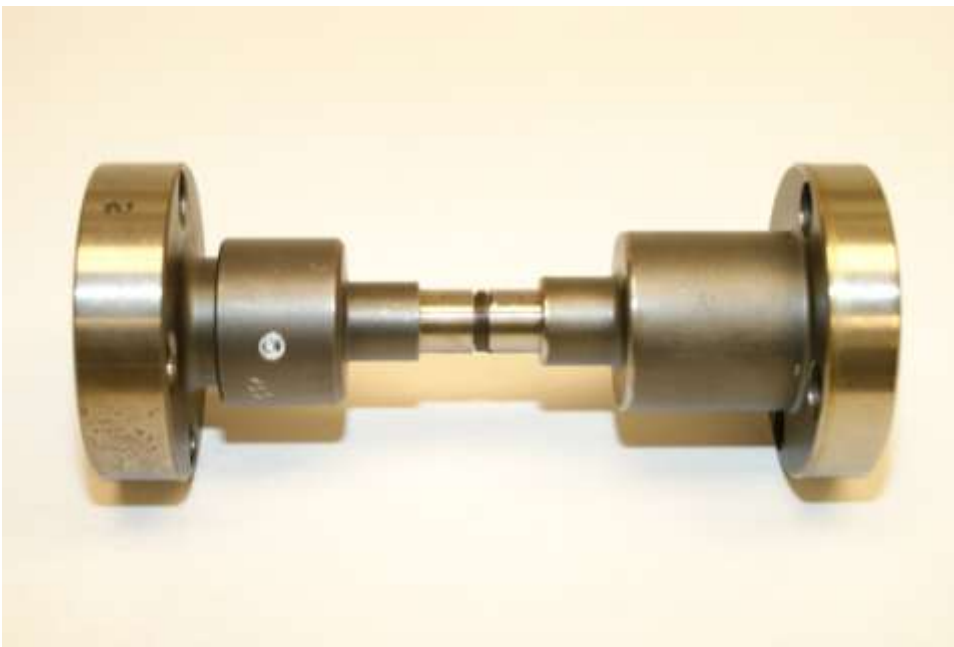

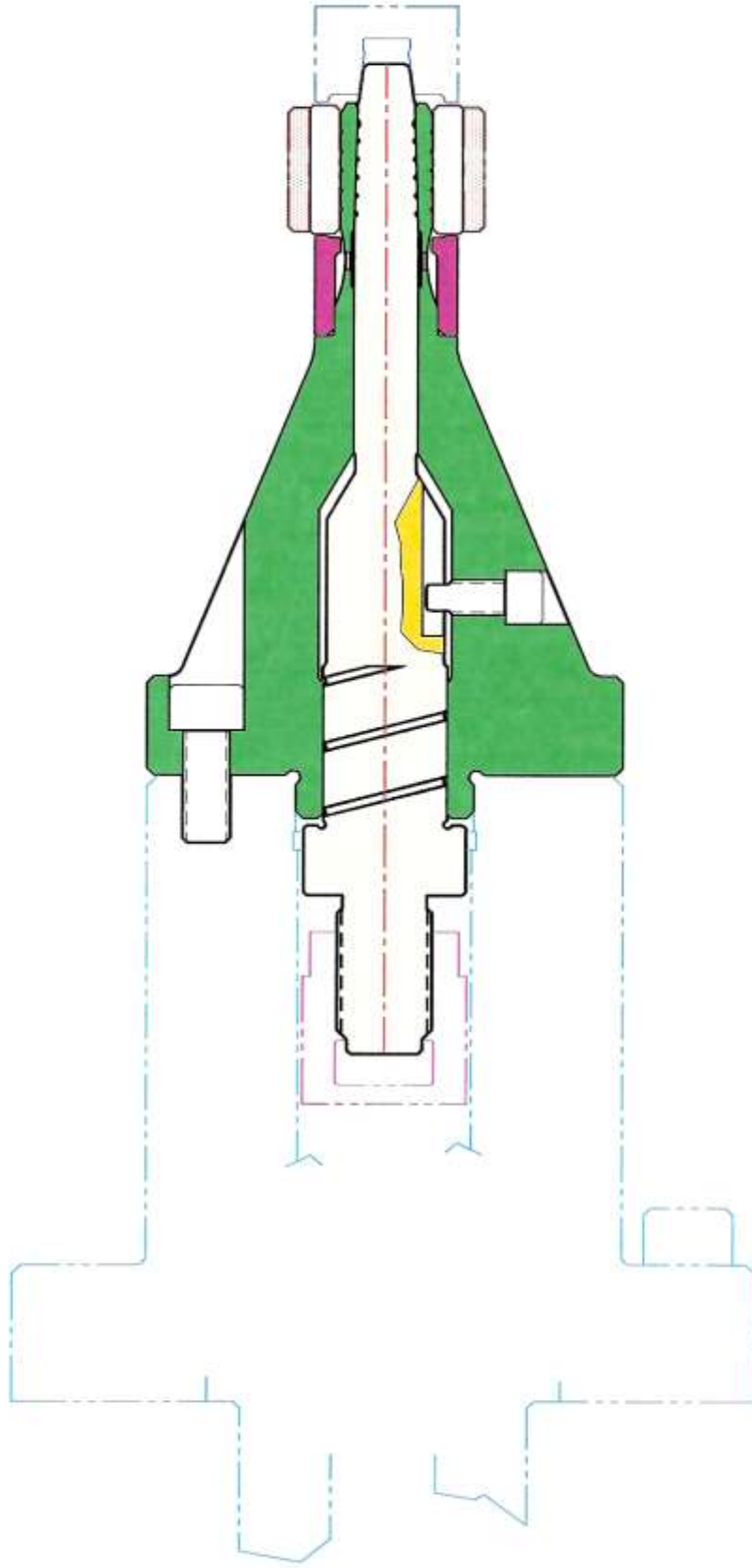

2192-STA

UJ **ULTRA-GRIP**
INTERNATIONAL
the ultimate in wheel handling
8155 RICHMOND ROAD, WALKER LAKE, MICHIGAN 48390

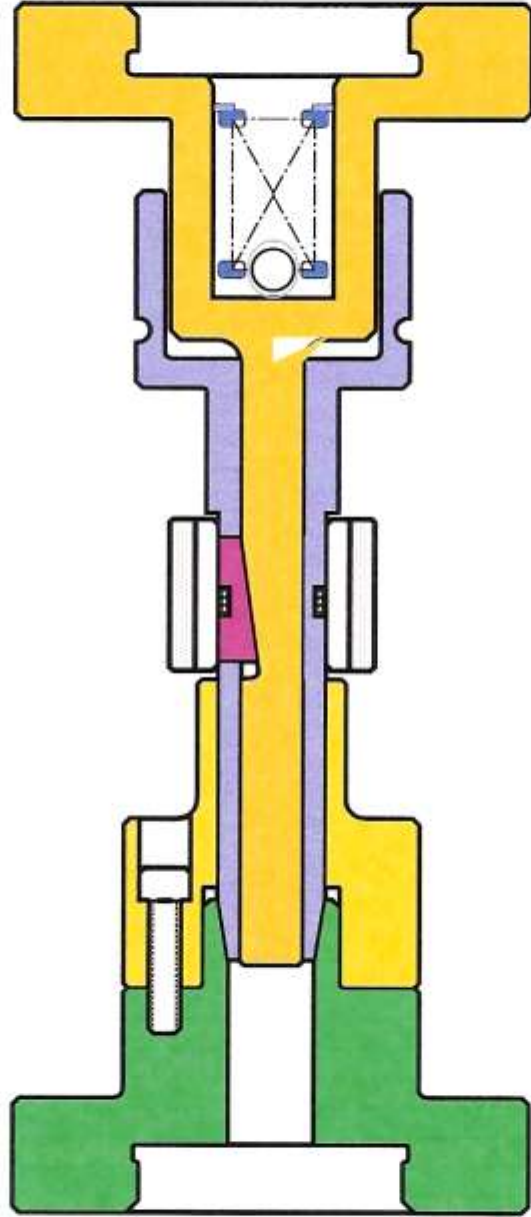

1768-SHA

U **ULTRA-GRIP**
INTERNATIONAL
the ultimate in wood handling
8155 RICHARDSON ROAD, VALLEJO LAKE, MICHIGAN 48389

Non-deforming pin arbors



- Multiple points of equalized pressure.
 - Pressure distributed evenly.
- Sealed design
 - Reduced maintenance
- Non-Pull back
 - Chuck design does not have part pull back.
- Ideal for thin walled parts
 - Improved part roundness.

Hydraulic and Pneumatic Cylinders



- Standard replacements for most major brands.
- Duplex/Large Thru-Hole/Variable Pressure Port
- Third Port Option for Coolant or Air Injection.
- Rear Flange Mounted Draw Tubes
- Provisions for Position Sensing



LARGE CHUCKS

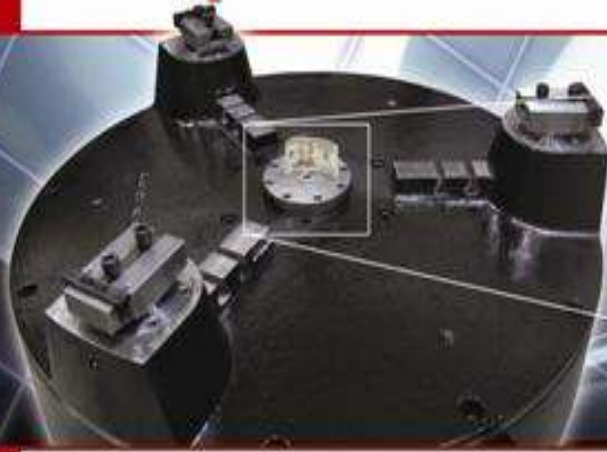

- Complete in-house design and manufacture
- Repair of your existing chucks
- Your single source for large chucking applications



Three/Four Jaw Manual power chuck

- Direct Mounting
- Individual jaw adjustment
- Centralizing
- Reversible jaw's
- Box jaw design
- Hardened and ground jaws
- Multiple "T" slot design
- Long master jaw design
- Cast Iron or steel body
- Special sizes available upon request



Three/Four Jaw manual power chuck Additional Features

Pre-hardened body

Optional pre-hardened cast iron or steel body which reduces costly repairs and improves overall chuck life.

Clamping Pressure

Assured high pressure clamping keeps even the largest parts secure during machining.

Special Designs

Special designs are available upon request. Please call for any application you may have.

Centralizing and Individual jaw adjustment

Three jaws centralize your part and each jaw can be adjusted independently allowing accurate part centering.

Standardized Components

We use common components wherever possible reducing customer inventory requirements.

Engineering Expertise

Ultra-Grip International offers the assistance of our experienced engineering department in the design of all your workholding requirements.

Box Jaws

Available box jaws for independent jaw adjustment and gripping.

Reversible Jaw Design

Grip ID or OD by simply removing screws and reversing the jaws.

Customer Assistance

Ultra-Grip's trained personnel provide immediate on-site customer service.



8155 Richardson Road Commerce Twp., Michigan 48390
248.363.0982 Fax 248.363.2057
Email: sales@ultra-grip.com Website: www.ultra-grip.com

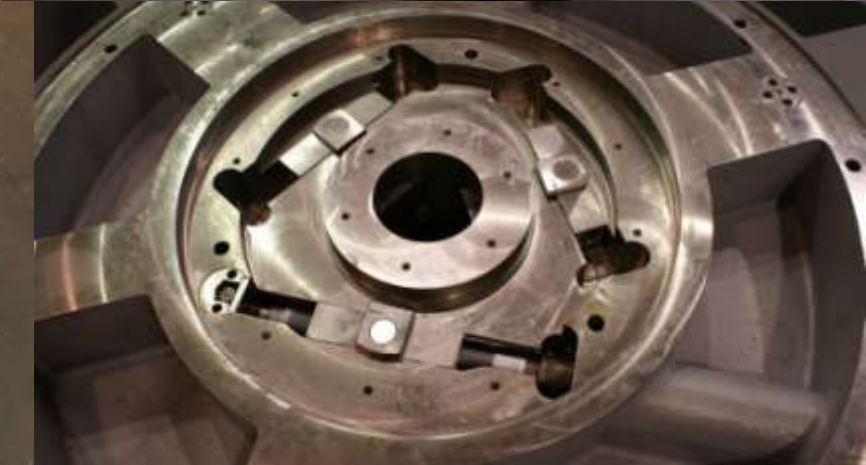



ULTRA-GRIP

INTERNATIONAL

Your Engineered Workholding Solution

Four-Jaw Independent

- ❑ Direct Mounting
- ❑ Individual jaw adjustment
- ❑ Reversible jaw's
- ❑ Hardened and ground jaws
- ❑ Multiple "T" slot design
- ❑ Long master jaw design
- ❑ Cast Iron or steel body
- ❑ Special sizes available upon request



Four-Jaw Independent Additional Features

Pre-hardened body

Optional pre-hardened cast iron or steel body which reduces costly repairs and improves overall chuck life.

Individual jaw adjustment

Each jaw can be adjusted allowing accurate part centering.

Special designs

Ultra-Grip International offers special designs to suite your part requirements.

Clamping Pressure

Assured high pressure clamping keeps even the largest parts secure during machining.

Long master jaw design

Our single piece long master jaw design enables greater part size capabilities.

Reversible Jaw Design

Grip ID or OD by simply removing screws and reversing the jaws.

Standardized Components

We use common components wherever possible in our various sizes of our Four-Jaw Independent Chucks, reducing customer inventory requirements.

Engineering Expertise

Ultra-Grip International offers the assistance of our experienced engineering department in the design of all your workholding requirements.

Customer Assistance

Ultra-Grip's trained personnel provide immediate on-site customer service.



8155 Richardson Road Commerce Twp., Michigan 48390

248.363.0982 Fax 248.363.2057

Email: sales@ultra-grip.com Website: www.ultra-grip.com



ULTRA-GRIP

INTERNATIONAL

Your Engineered Workholding Solution

Large Bore Chucks

- ❑ Effectively grip up to 22" O.D. and larger upon request.
- ❑ 1.25" per jaw travel for ease of loading over flange collars.
- ❑ Versatile master jaw design, allows for the use of many standard styles of top jaws.
- ❑ Quick acting double angle master jaws.
- ❑ Self-Contained design eliminates the need for drawbar and special air packs.
- ❑ Quick change spring clamp design eliminates costly seals, check valves, and reduces chuck maintenance.



Power Chucks

Large Bore Chuck Additional Features

Sealed Design

Eliminates costly maintenance and down time, increasing machine time, productivity and profits.

Quick Change Adjustable Clamping Pressure

The entire spring pack can be quick changed to increase or decrease chuck clamping pressure, minimizing distortion.

Standardized Components

We use common components wherever possible in our various sizes of LBC Chucks, reducing customer inventory requirements.

Easy Mounting

Air distributor ring is mounted and contained within the spindle mounting adaptor.

Center Guide Bushing

Prevents damage to top jaws while loading pipe through the center of the chuck.

Engineering Expertise

Ultra-Grip International offers the assistance of our experienced engineering department in the design of all your workholding requirements.

Special Grease Lubrication

High pressure grease for increase lubrication of internal components.

Reversible Jaw Design

One set of reversible jaws with grippers on both ends will handle a variety of pipe diameters.

Customer Assistance

Ultra-Grip's trained personnel provide immediate on-site customer service.



8155 Richardson Road Commerce Twp., Michigan 48390

248.363.0982 Fax 248.363.2057

Email: sales@ultra-grip.com Website: www.ultra-grip.com



ULTRA-GRIP

INTERNATIONAL

Your Engineered Workholding Solution

Large Bore Chucks

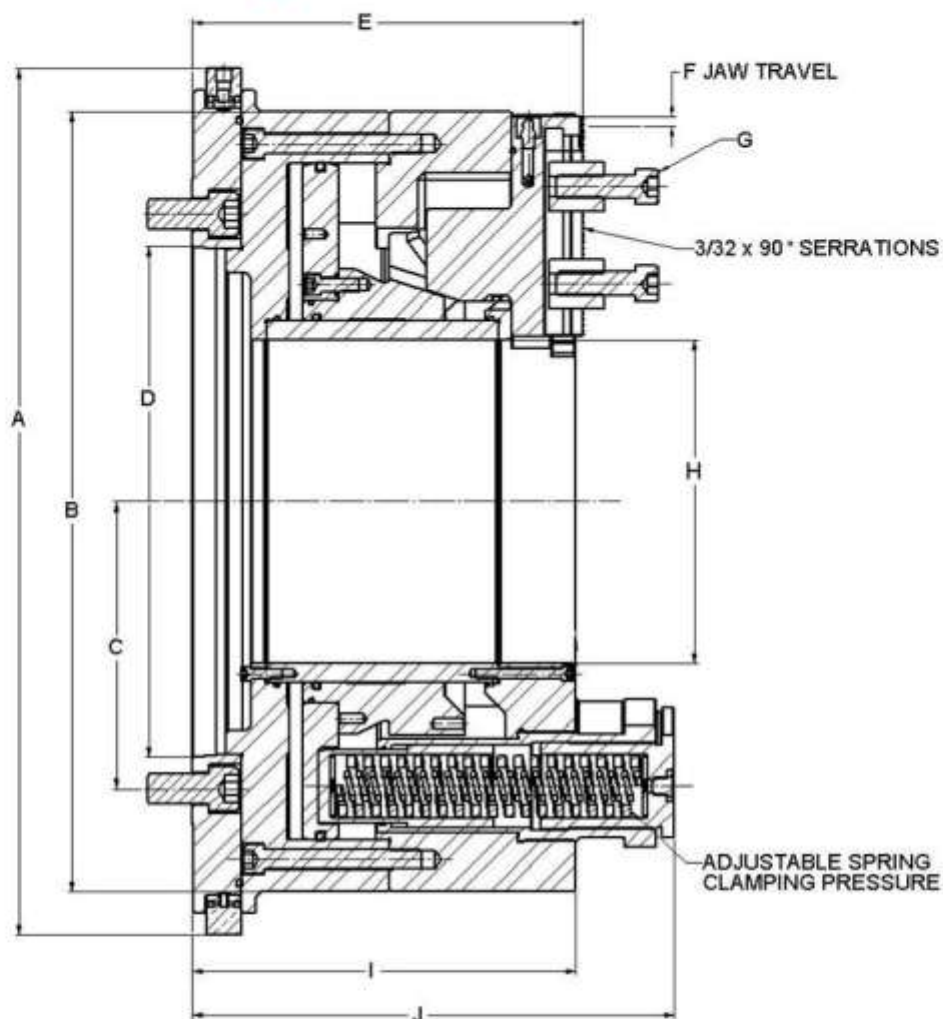

CHUCK SIZE	20"	24"	39"
MODEL NUMBER	LBC-20000	LBC-24000	LBC-39000
DIM A	23.50	27.50	39
DIM B	20.75	24.75	36.25
DIM C	9.13	9.13	9.13
DIM D	JIS-20	JIS-20	JIS-20
DIM E	12.41	12.41	13.00
DIM F	.75	1.00	1.00
DIM G	3/4-10	3/4-10	1.00-8
DIM H	9.25	10.25	21.10
DIM I	12.17	12.17	13.25
DIM J	15.31	15.31	16.40

UBG 3 INNER 3 OUTER

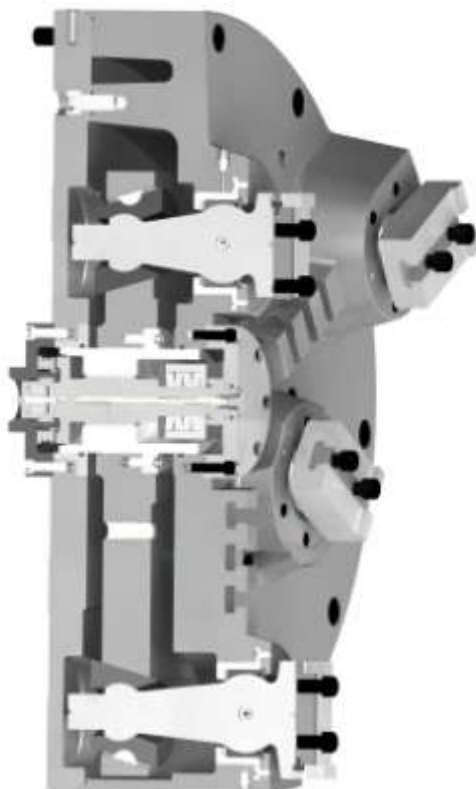

- ❑ Grip multiple diameters with the same chuck.
 - Reduced costs and setup times by utilizing the same chuck for a family of parts.
- ❑ Grip I.D. in one operation and O.D. in the other operation with the same chuck.
- ❑ Multiple methods of actuation.
 - Drawbar
 - Screw type
 - Self Contained Air or Hydraulic

ULTRA-GRIP INTERNATIONAL

the ultimate in workholding

LARGE DIAMETER CHUCKS

IN THE WORLD OF WORKHOLDING, DON'T BE AFRAID TO...
THINK BIG

When it comes to precision machining, Ultra-Grip International provides real solutions for those **BIG** workholding problems— offering a **complete** line of oversized power chucks up to 96 inches (2-1/2 meters) in diameter!

Regardless of your large-scale application requirements, we have the knowledge, the experience and the capabilities to meet your biggest expectations.

That's why, since its beginnings in 1990, Ultra-Grip has become a giant in the workholding industry, equipping production facilities across the globe with the highest quality, most accurate, reliable chucks available on the market, at a quality price, on time, and with the reputation for unparalleled service and customer satisfaction.

Do you have one of those "impossible" projects no one else seems willing to touch? No problem at Ultra-Grip International. Our team of highly qualified engineers will work **directly** with you on the planning and design that best fits your specific manufacturing needs.

Combining over a century of total workholding experience with

the latest technology available, you are guaranteed the best and most appropriate design available, resulting in big savings both in cycle times and overall production costs.

Because Ultra-Grips chucks are manufactured in-house by our parent company, Three M Tool & Machine, we are able to ensure that same top quality throughout our product line.



Large workholding applications are brought down to size with Ultra-Grip International's heavy-duty capabilities. Backed by our fully equipped facility, state-of-the-art machining technology and environmentally controlled inspection room, UGI is able to routinely manufacture power chucks up to 96 inches in diameter, while holding tolerances as close as .0001 of an inch.



Three M has been a leader in the machining industry for over 30 years. Its large state-of-the-art facility weighs in with the heavy equipment you need to move that big project, along with the quality control that makes the most stringent accuracy requirements routine.

But we don't stop at just providing you the biggest and best chucks available. We'll also work to refurbish your worn out or broken workholding products, no matter who made them. With our manufacturing expertise and capabilities we are able to check, repair and even rebuild our competitor's products to better than new condition, regardless of make or complexity.



In the end, however, it is the uncompromising attention we pay to you, our customers, that has made Ultra-Grip such a big name in the chucking industry.

Our customer service will assure your satisfaction both during and after the sale.

We don't just talk big. We are big – committed to giving you the biggest and best there is. So when you need to get a grip on that large project, look to those who can give you the power you need... look to the *Ultimate in Workholding*... look to Ultra-Grip International.



**Manufactured and
Assembled in the
U.S.A.**



Milling fixtures



Air operated

Spring clamp/air open

Hydraulic operated

Two way hydraulic

Hydraulic open spring clamp

Hydraulic check valve
system

Manually operated

Ultra-Grip International

- Complete source for all your work holding needs
- Service after the sale
- Engineering driven company
- Customer oriented
- Privately owned and operated.

Applications

Turbo Housing



**Three-Jaw UBG compensating
with a centralizing collet chuck**

Gear Shaving

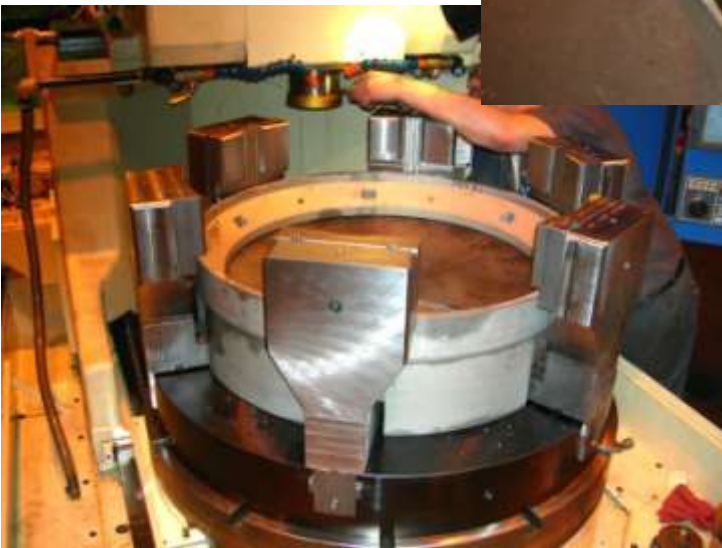

Six jaw sliding jaw chuck

Gear grinding



Pitch-line diaphragm with Interchangeable gear cages



Quick change diaphragm with Interchangeable top jaws

Clutch Housings



**Six jaw UBG pressure
equalizing chucks**

Thin walled turning



Face clamping chuck

A/C housings



Three-Jaw UBG

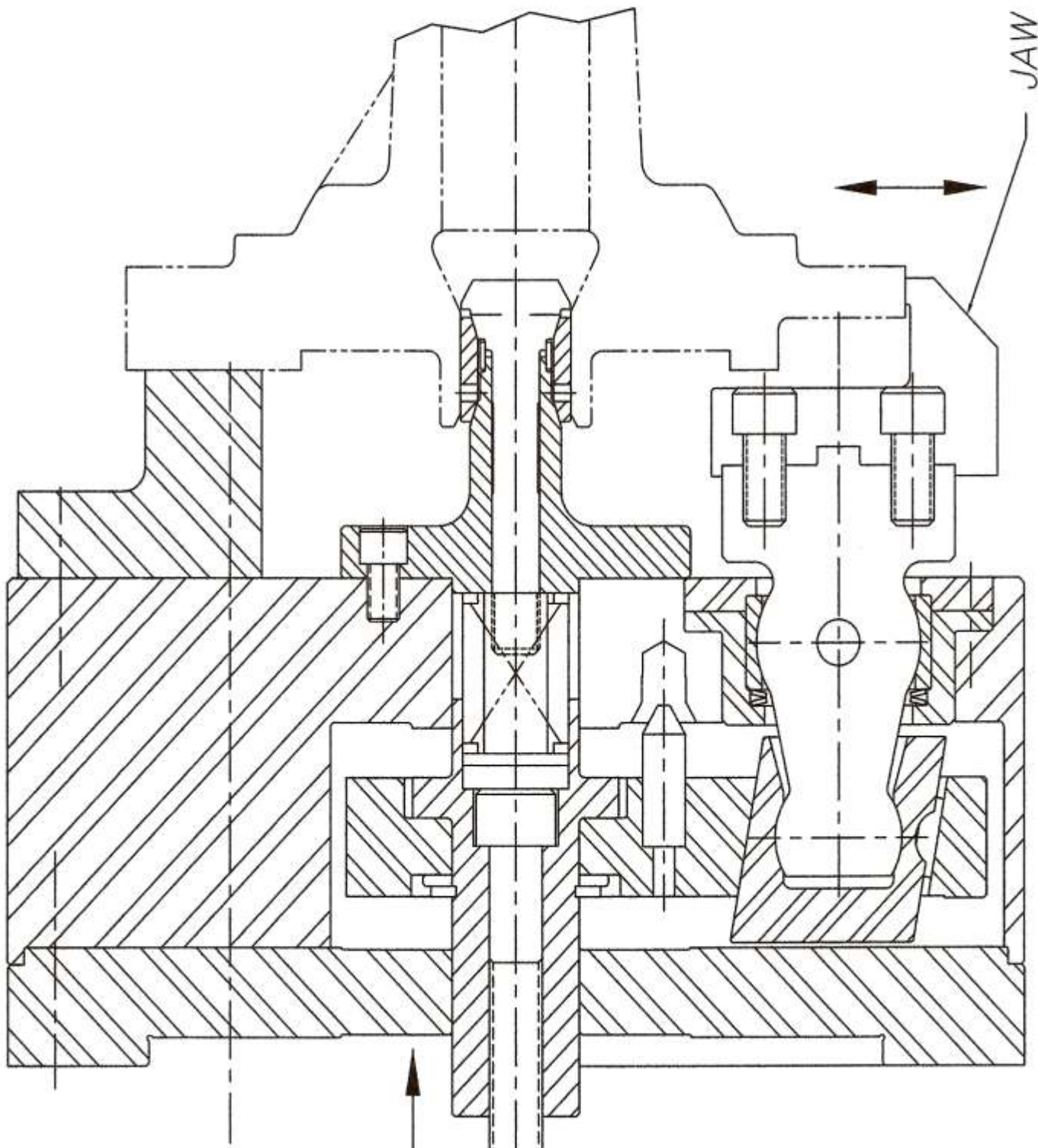

COMPENSATING BALL-LOCK CHUCK
WITH SPRING ACTUATED MANDREL

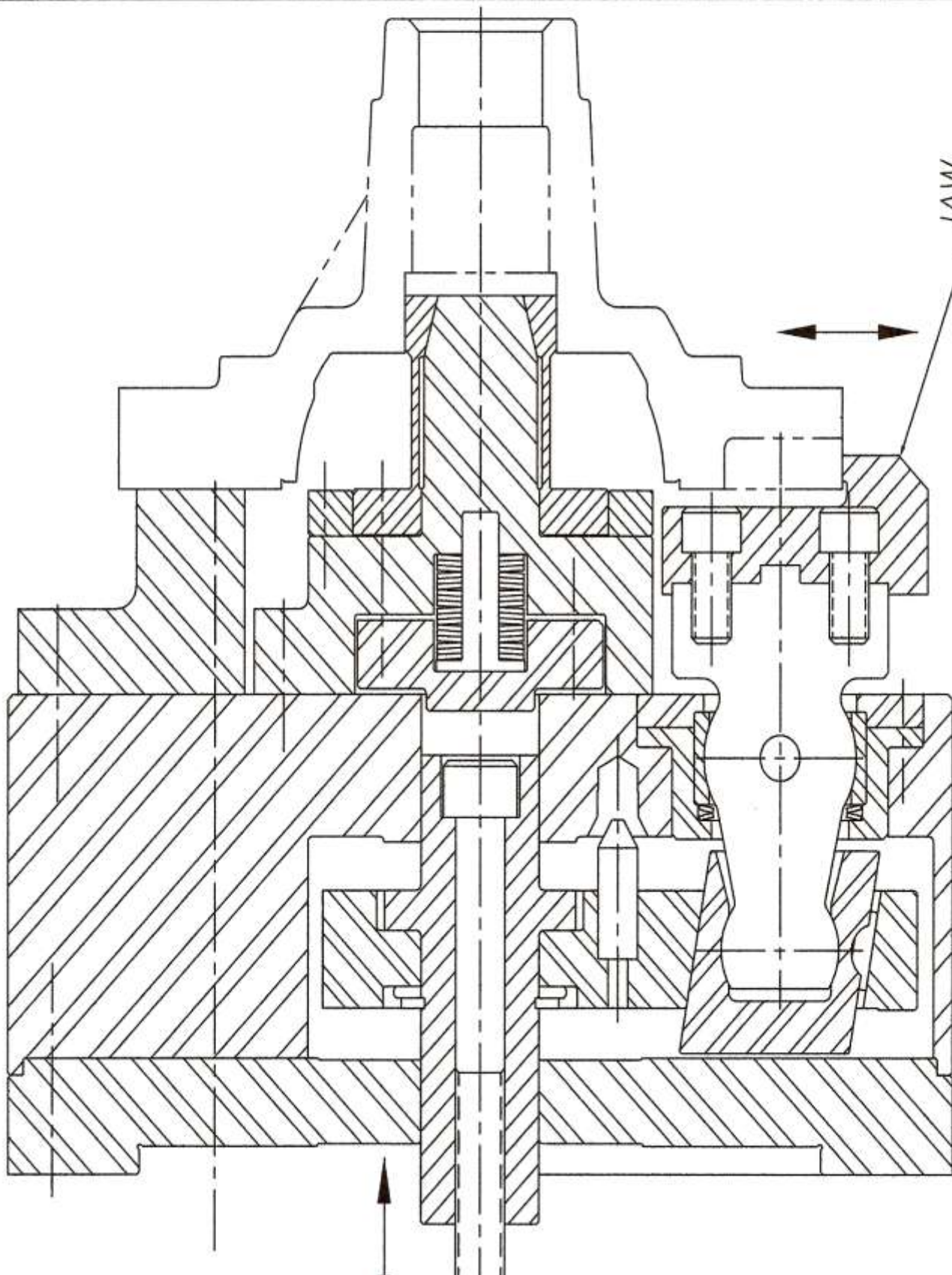

COMPENSATING CHUCK WITH ARBOR

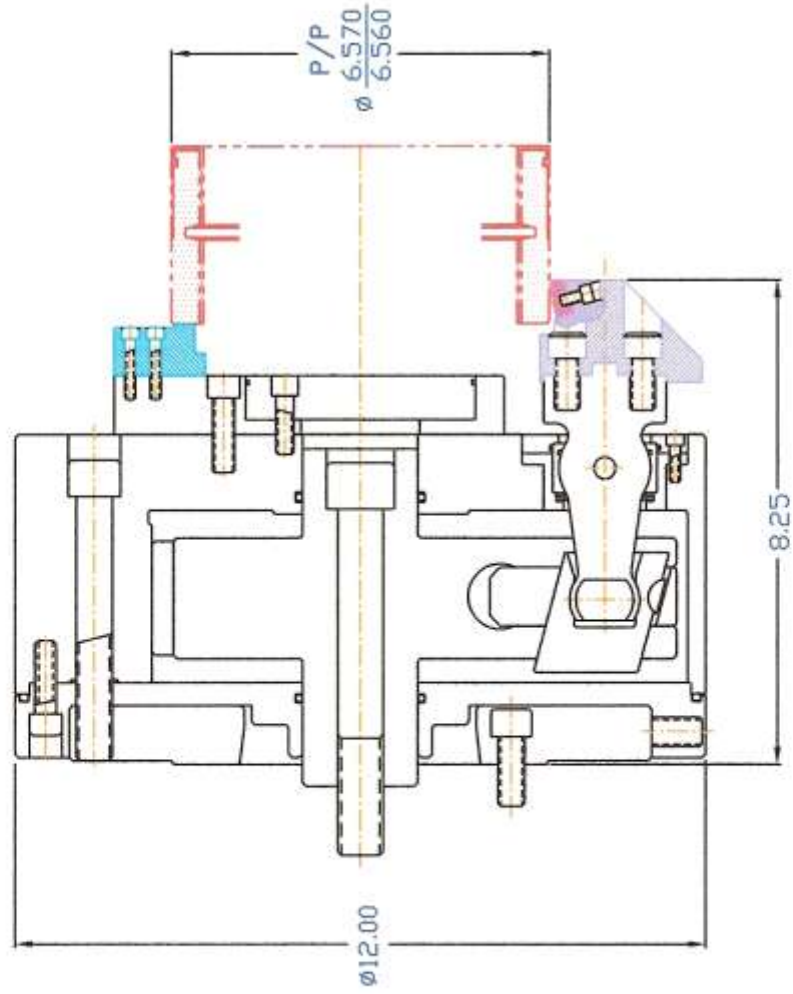
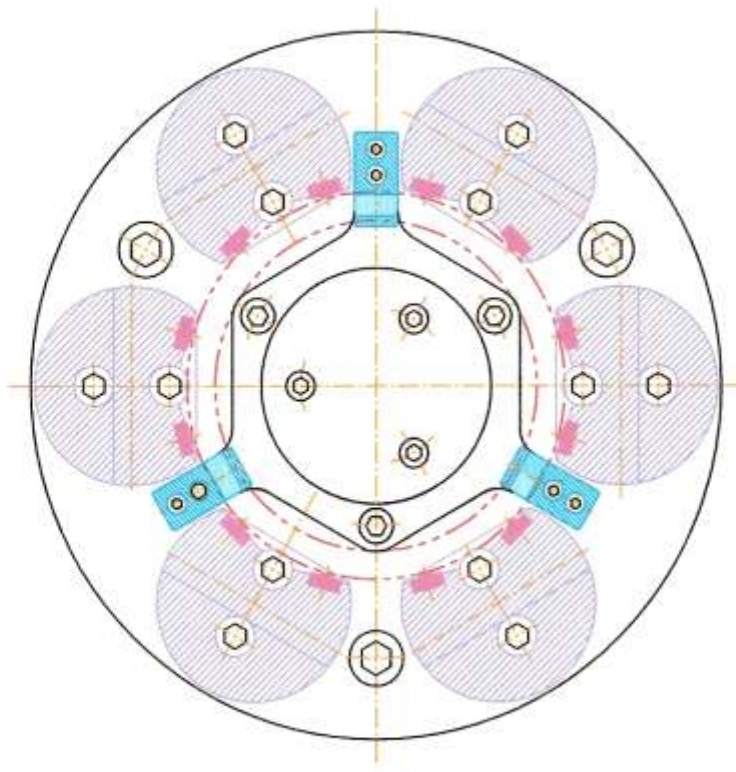

PART NAME: BLANK ANNULUS GEAR

OPERATION: ROUGH AND FINISH TURN BORE CONTOUR, ROUND WITHIN .001, HALF O.D. CONTOUR AND END FACE.

PRODUCT: 12.00" (6-JAW) O.D. GRIP EQUALIZING "BALL-GRIP" POWER CHUCK ASSEMBLY, DRAWBAR OPERATED.

LOCATION: JAWS WITH CARBIDE INSERTS GRIP AND EQUALIZE ON O.D. AT (12) EQ. SPACED POINTS, PULL BACK HOLDS PART RIGID AGAINST (3) LOCATOR BLOCKS.

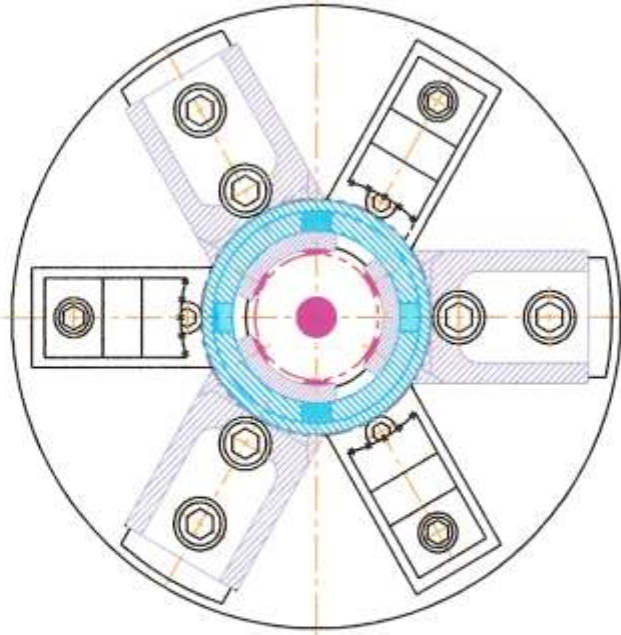
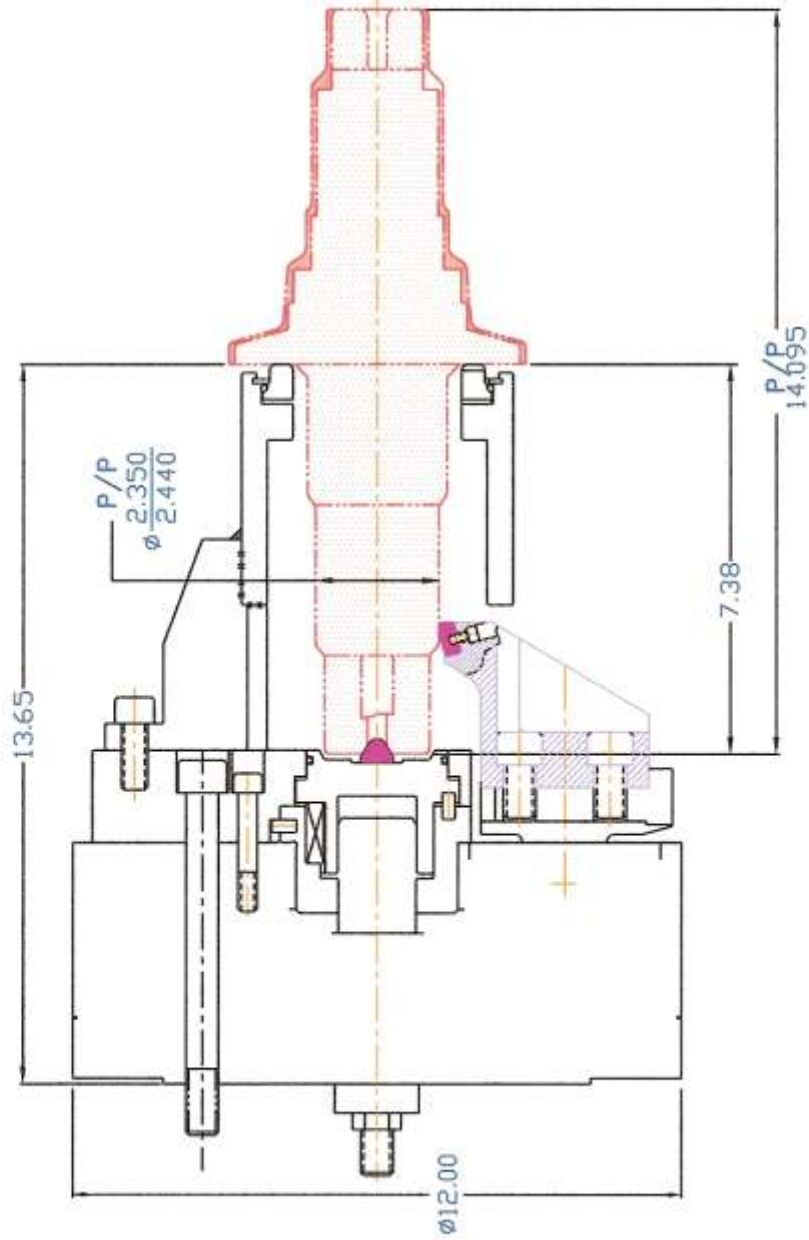

PART NAME: TRUCK DRIVE SHAFT

OPERATION: TURN HALF OF O.D. CONTOUR.
PRODUCT: 12" (3-JAW) O.D. GRIP COMPENSATING BALL CHUCK ASSEMBLY, WITH SPRING LOADED CENTER ASSEMBLY AND ROCKER STOP.
LOCATION: PART CENTRALIZED BETWEEN CENTERS, JAWS GRIP ON O.D. TO DRIVE PART AND END LOCATED WITH FIXED ROCKER STOP.

2120-UBG

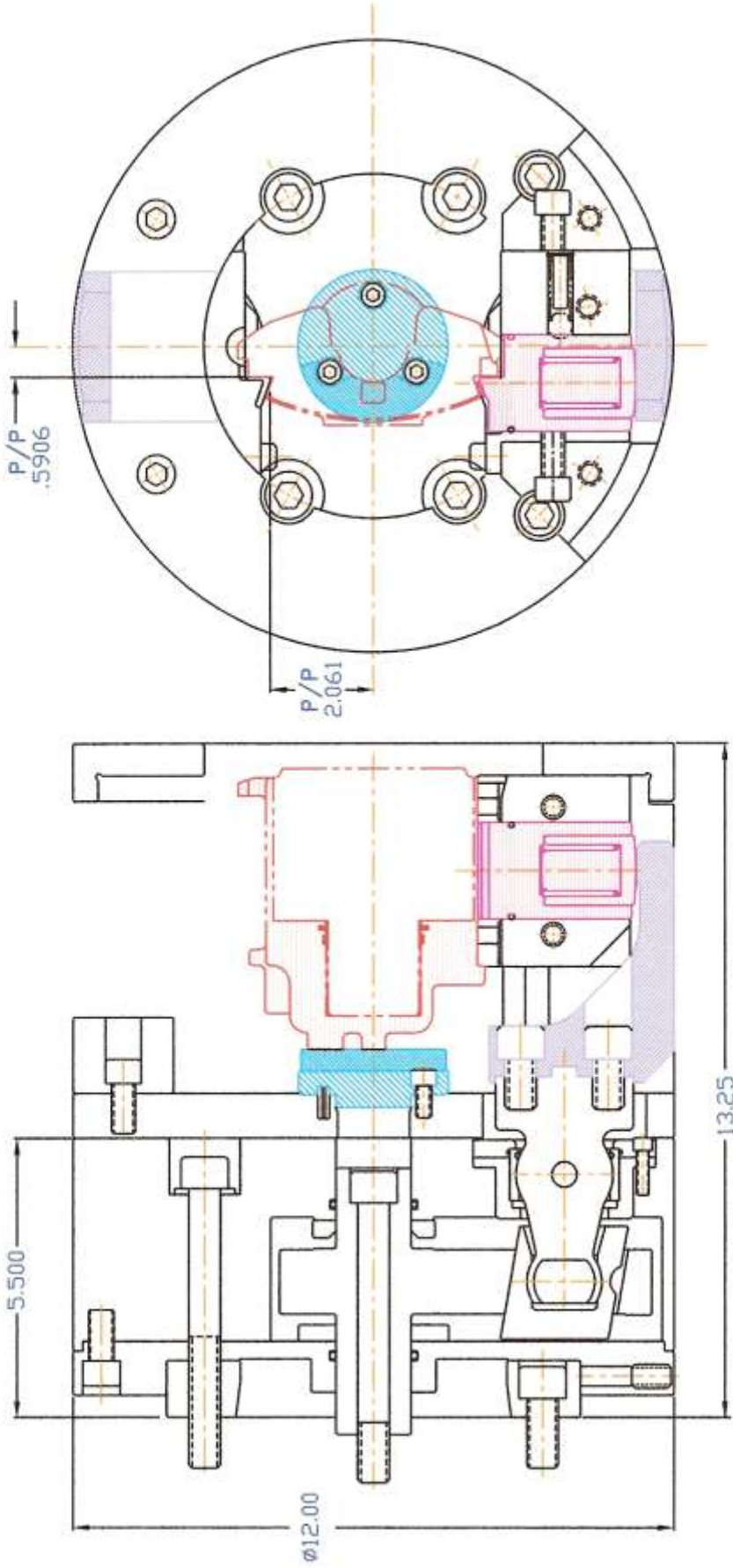

PART NAME: CALIPER HOUSING

OPERATION: ROUGH AND FINISH MACHINE BORE CONTOUR
PRODUCT: 12" (2-JAW) EXTERNAL CENTRALIZING
 "BALL-GRIP" POWER CHUCK ASSEMBLY,
 DRAWBAR OPERATED, WITH SPECIAL
 CLAMPING CARTRIDGES.

LOCATION: PART CENTRALIZED ON SPECIFIED DATUMS,
 AND END LOCATED WITH FIXED LOCATOR.

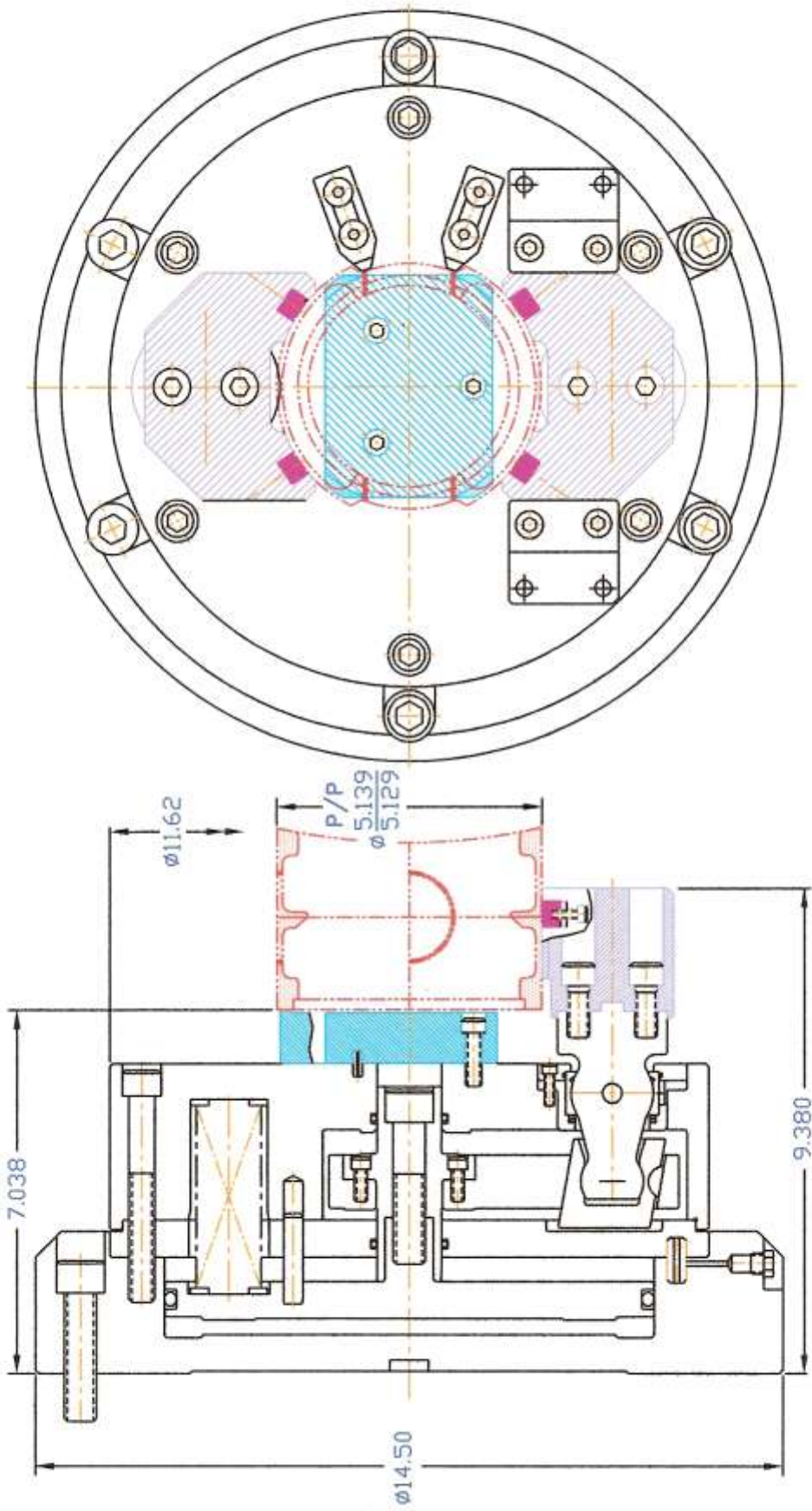

PART NAME: SKIRT-CROSSHEAD PISTON

OPERATION: CORE DRILL & ROUGH BORE (2) PIN HOLES.
PRODUCT: 12" (2-JAW) O.D. GRIP CENTRALIZING
 BALL-GRIP POWER CHUCK ASSEMBLY,
 HYDRAULIC OPEN, SPRING CLAMP.
LOCATION: JAWS GRIP ON O.D. TO CENTRALIZE PART,
 PULL BACK HOLDS PART RIGID AGAINST
 LOCATOR.

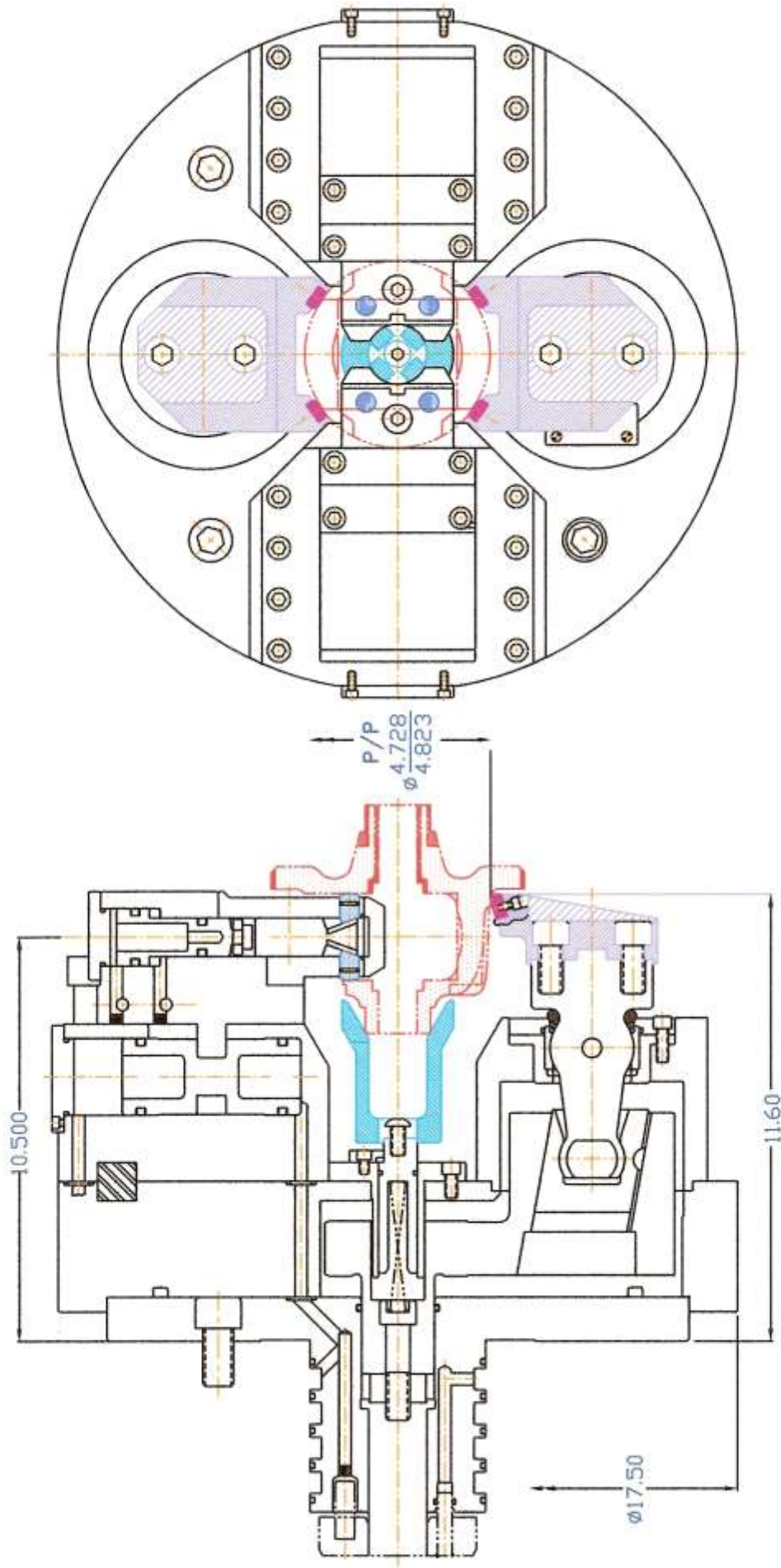

PART NAME: DIFFERENTIAL CASE

OPERATION: TURN FLANGE DIA, FACE HUB, ROUGH TURN HUB,ROUGH FACE HUB STEP, BORE FRONT HUB BORE,CHAMFER,REVERSE C'BORE, CHAMFER & FACE.

PRODUCT: 17.50" (2-JAW) EXTERNAL CENTRALIZING BALL GRIP POWER CHUCK, DRAWBAR OPERATED WITH (2) HYDRAULIC ACTUATED SLIDES.

LOCATION: PART IS GRIPPED & CENTERED WITH (2) JAWS AND SPRING LOADED FEMALE CENTERWISE LOCATION ESTABLISHED IN CAST WINDOWS WITH (2)SLIDING HYDRAULIC CLAMPING UNITS.

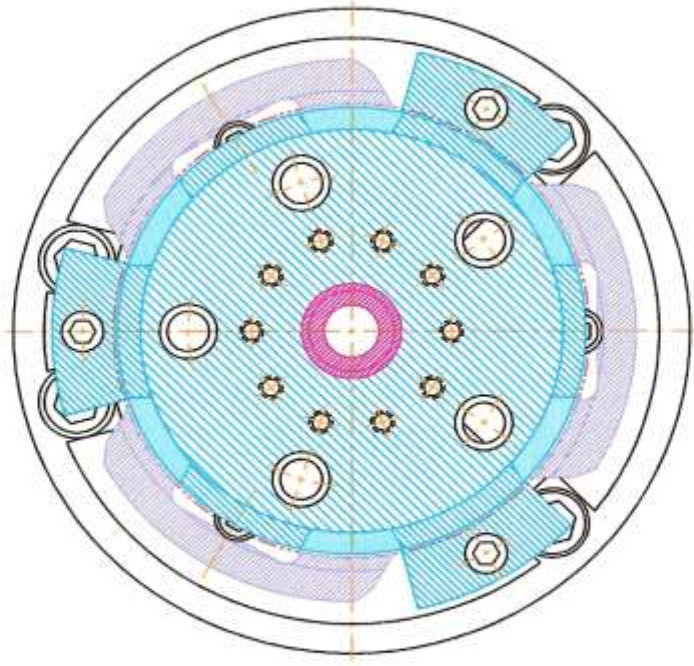
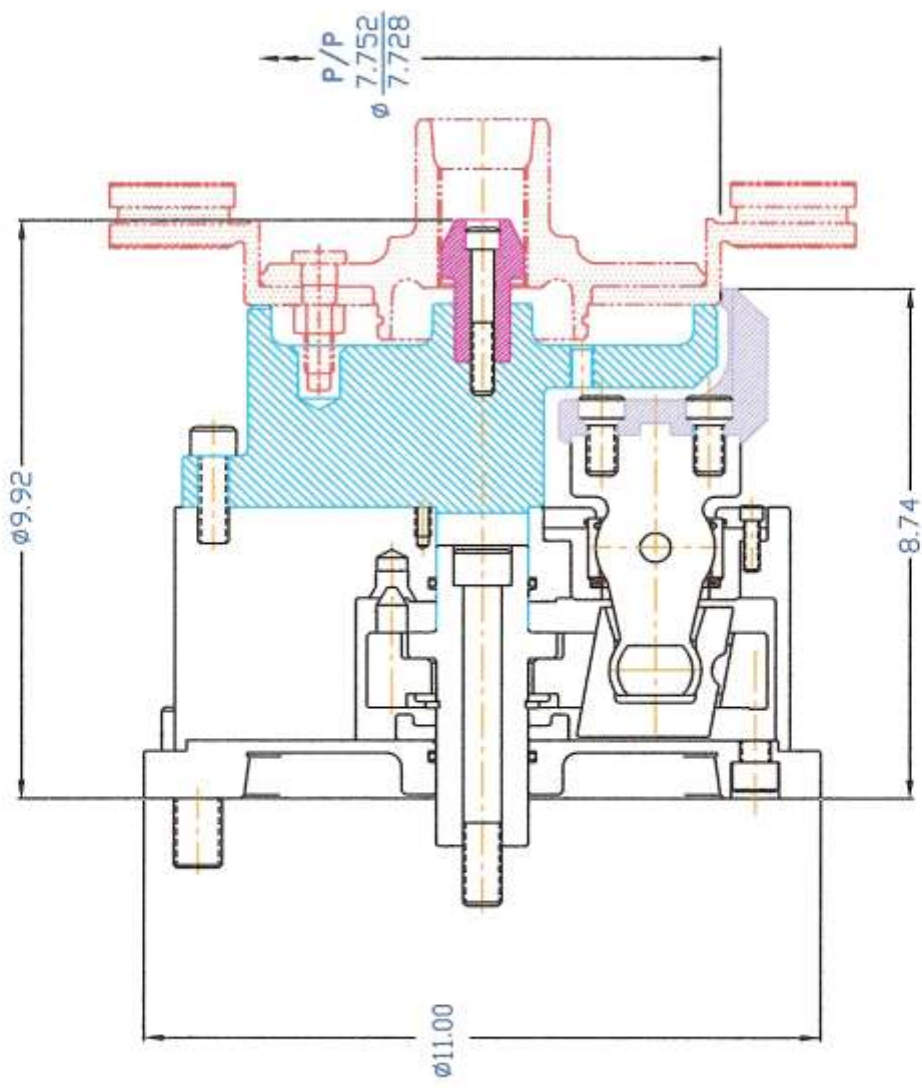

PART NAME: HUB & ROTOR ASSEMBLY

OPERATION: MACHINE BRAKE SURFACES.
PRODUCT: 10" (3-JAW) EXTERNAL COMPENSATING
 "BALL-GRIP" POWER CHUCK ASSEMBLY,
 DRAWBAR OPERATED.
LOCATION: CENTER PLUG LOCATES PART, JAWS GRIP
 ON O.D., PULL BACK HOLDS PART RIGID
 AGAINST LOCATOR RING.

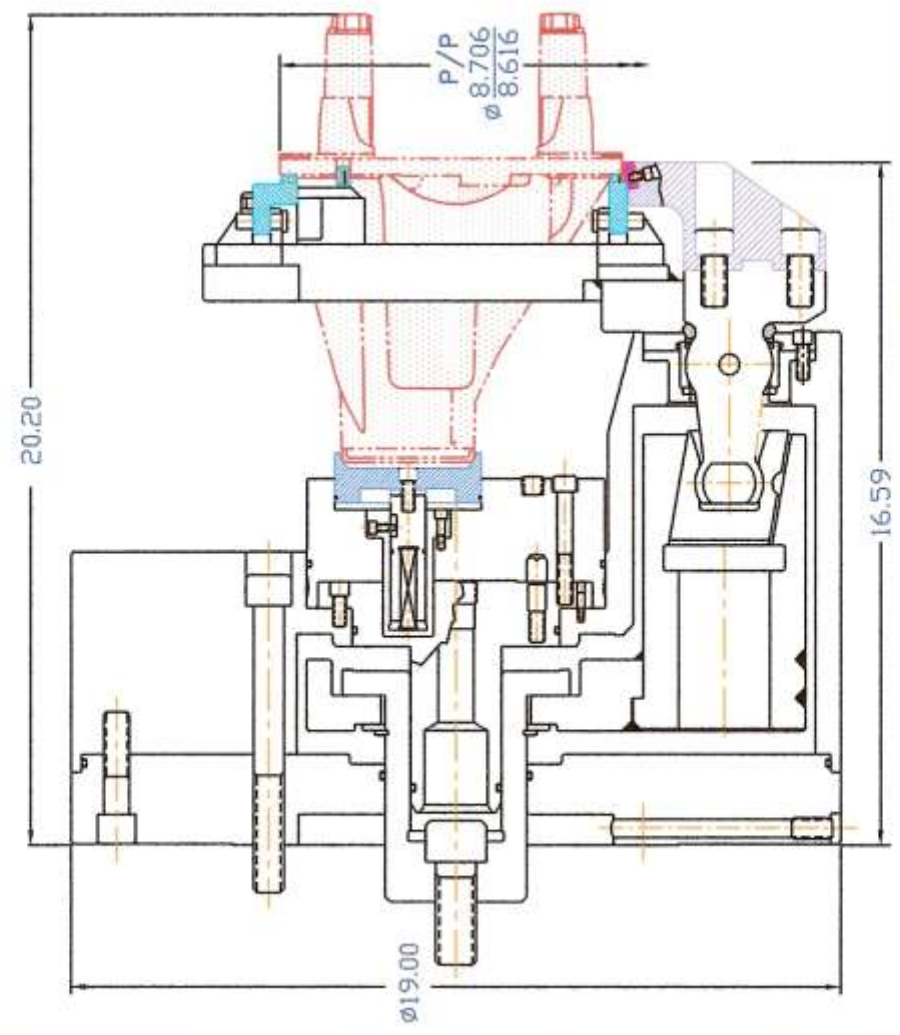
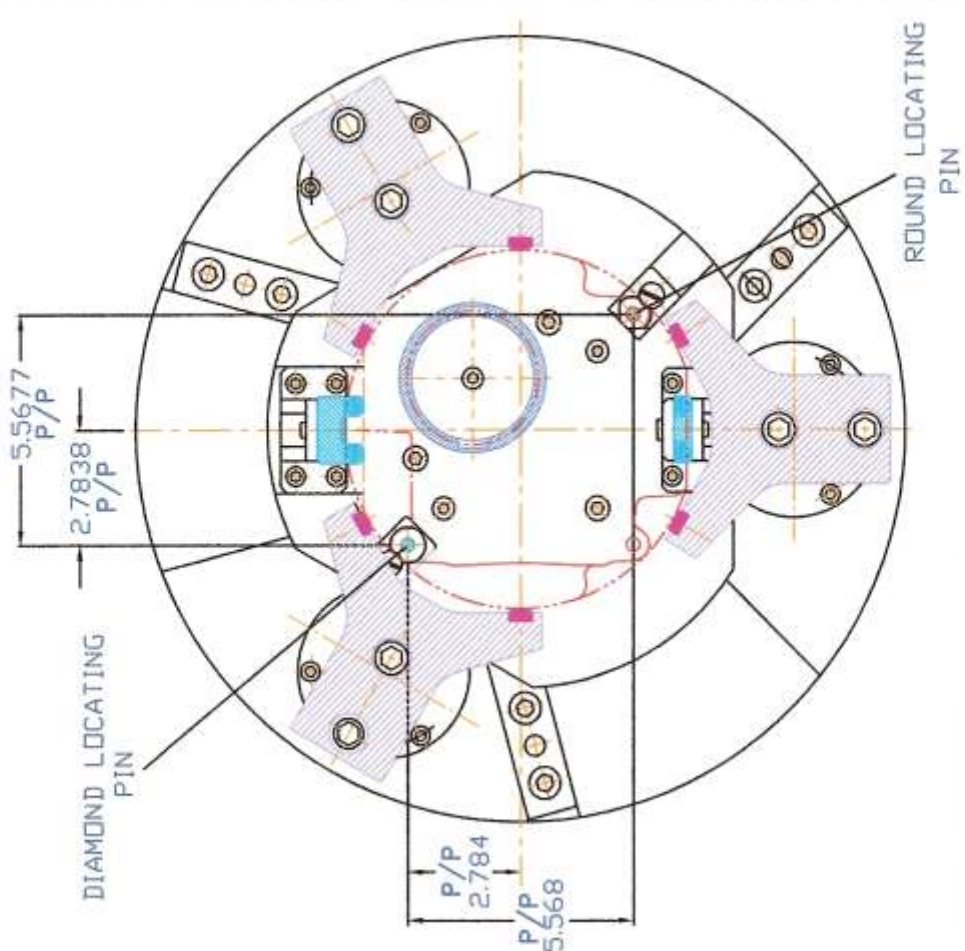

PART NAME: DIFFERENTIAL CASE HOUSING

OPERATION: TURN FLANGE DIA. AND FACE BORE ASSEMBLED BEARING CAPS.

PRODUCT: SPECIAL TOWERED (3) JAW COMPENSATING "BALL-GRIP" CHUCK, DRAWBAR OPERATED.

LOCATION: PART IS LOCATED IN DATUM HOLES WITH (1) ROUND & (1) DIAMOND PIN COMPENSATING JAW'S GRIP CAST FLANGE O.D. AND PART END LOCATED ON ROCKER STOPS. PART IS ALSO SUPPORTED WITH SPRING LOADED RING (OFF CENTERED).

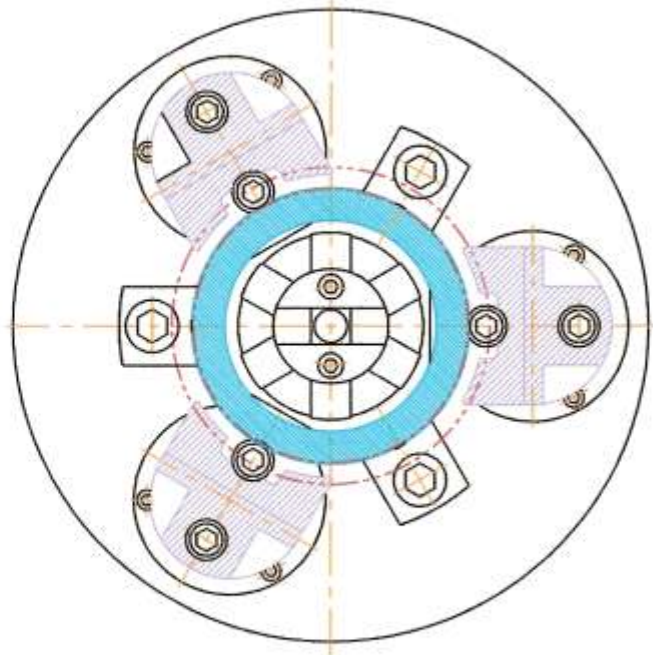
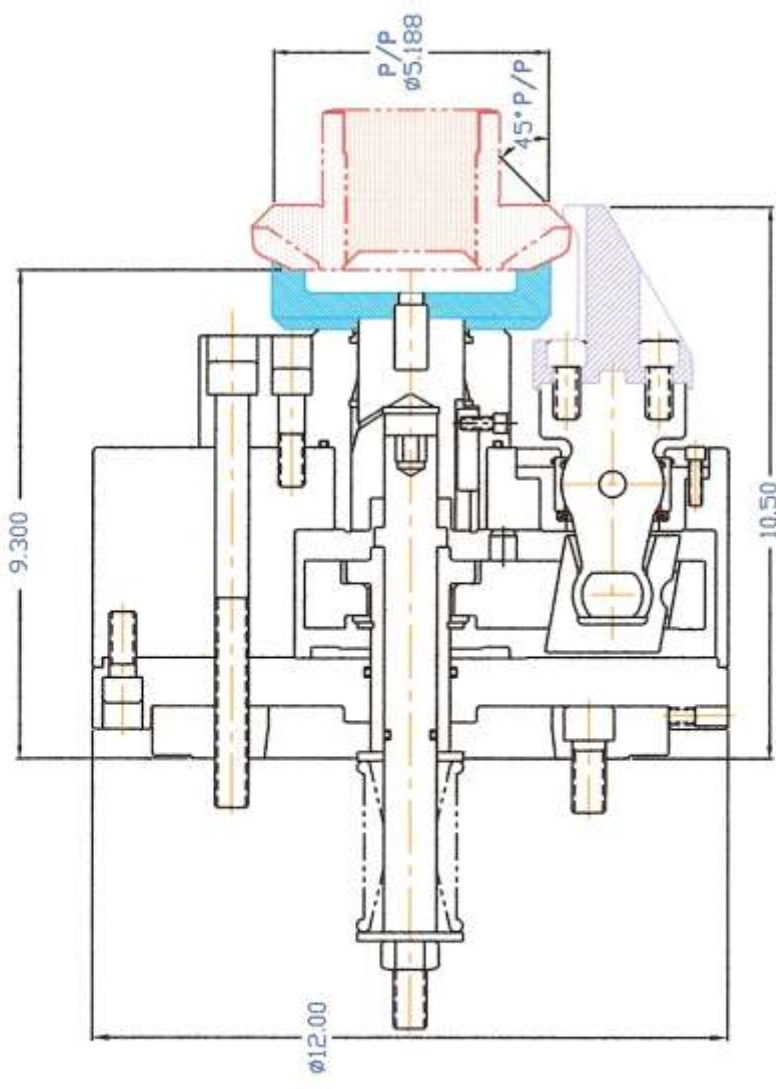

PART NAME: DIFFERENTIAL SIDE GEAR

OPERATION:

WITH GEAR NEST FORWARD AND TAIL STOCK RAM CLAMPING PART PIECE IN NEST REMOVE FLASHING. GENERATE 45° ANGLE AND TURN HUB O.D. AND SHOULDER FACE; AND WITH GEAR NEST RETRACTED AND CHUCK JAWS CLAMPING PART PIECE TURN HUB FACE, DRILL, BORE, AND CHAMFER.

PRODUCT:

12.00" (3-JAW) EXTERNAL COMPENSATING BALL-GRIP POWER CHUCK ASSEMBLY, DRAWBAR OPERATED.

LOCATION:

PART CENTRALIZED IN GEAR NEST AND CLAMPED WITH (3) JAWS.

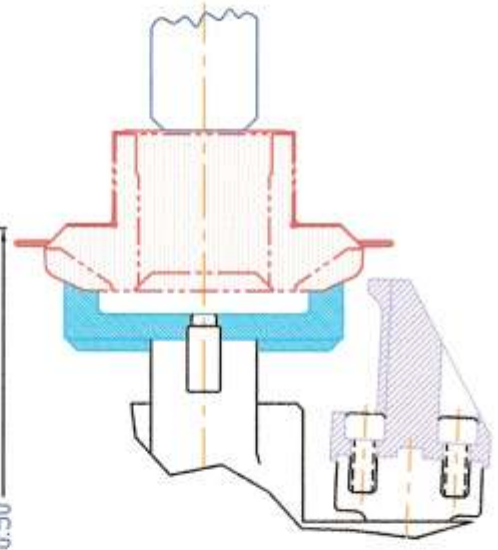

2110-UBG

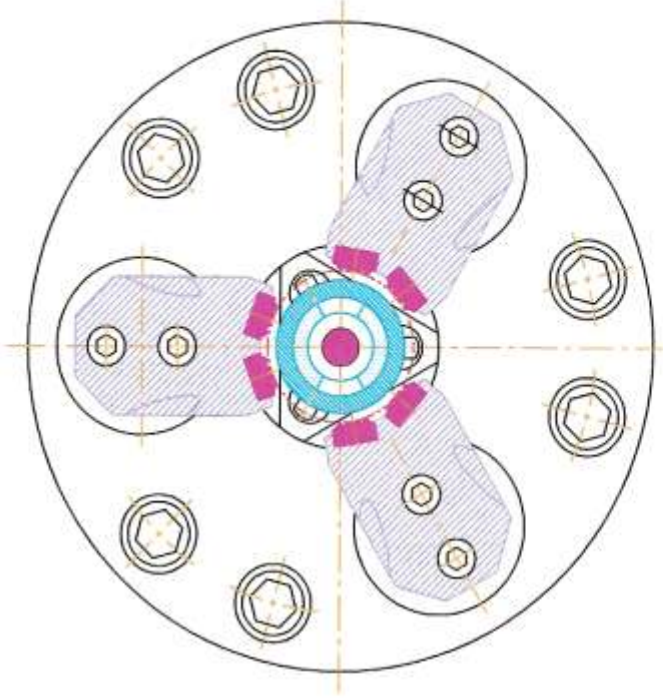
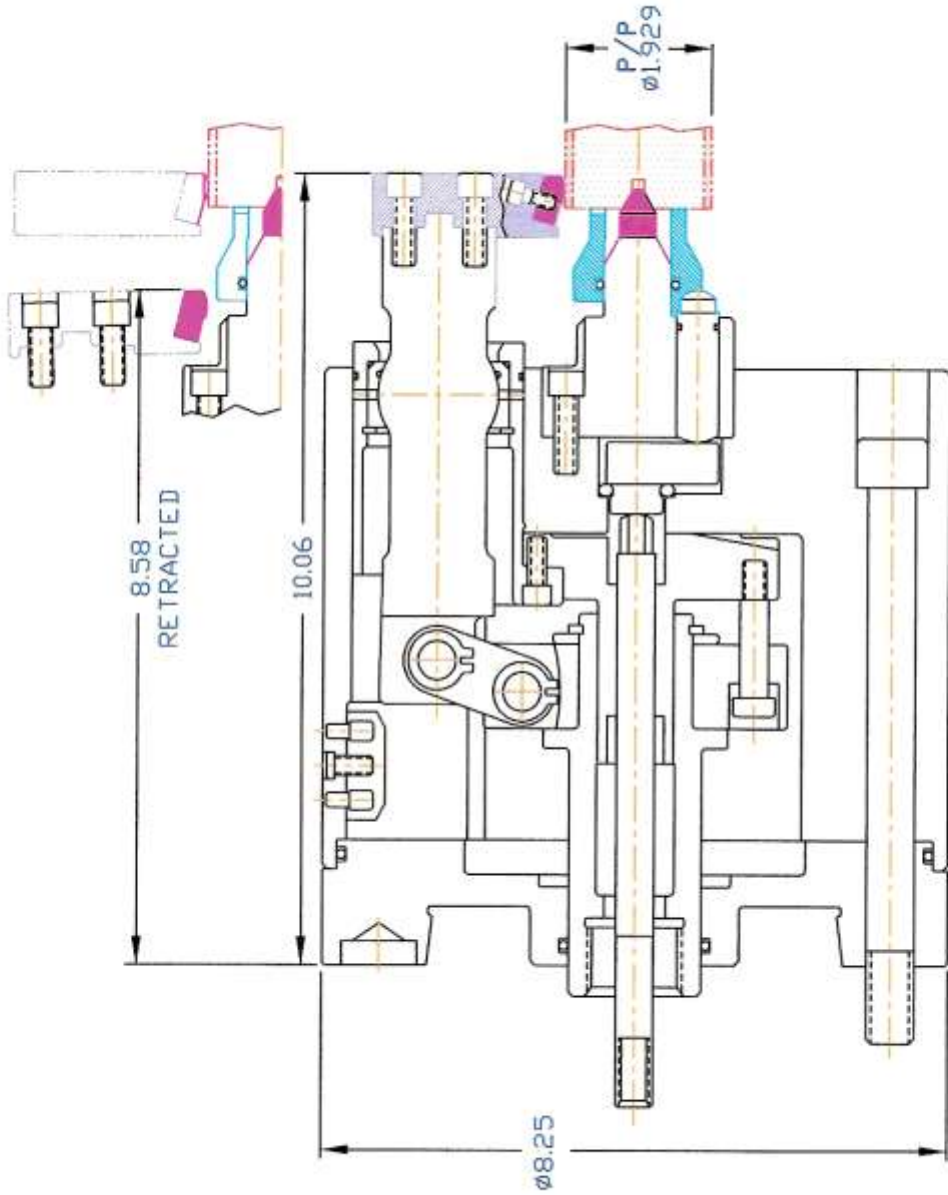

PART NAME: PUMP SHAFT

OPERATION: TURN SHAFT O.D. CONTOUR COMPLETE.

PRODUCT: 8" RETRACTABLE COMPENSATING POWER CHUCK WITH DRAWBAR OPERATED FACE DRIVER ASSEMBLY.

LOCATION: PART LOCATED BETWEEN CENTERS, JAWS GRIP ON O.D. FOR DRIVE TO MACHINE O.D. CONTOUR, RETRACT JAWS AND FACE DRIVER DRIVES PART TO COMPLETE OPERATION.

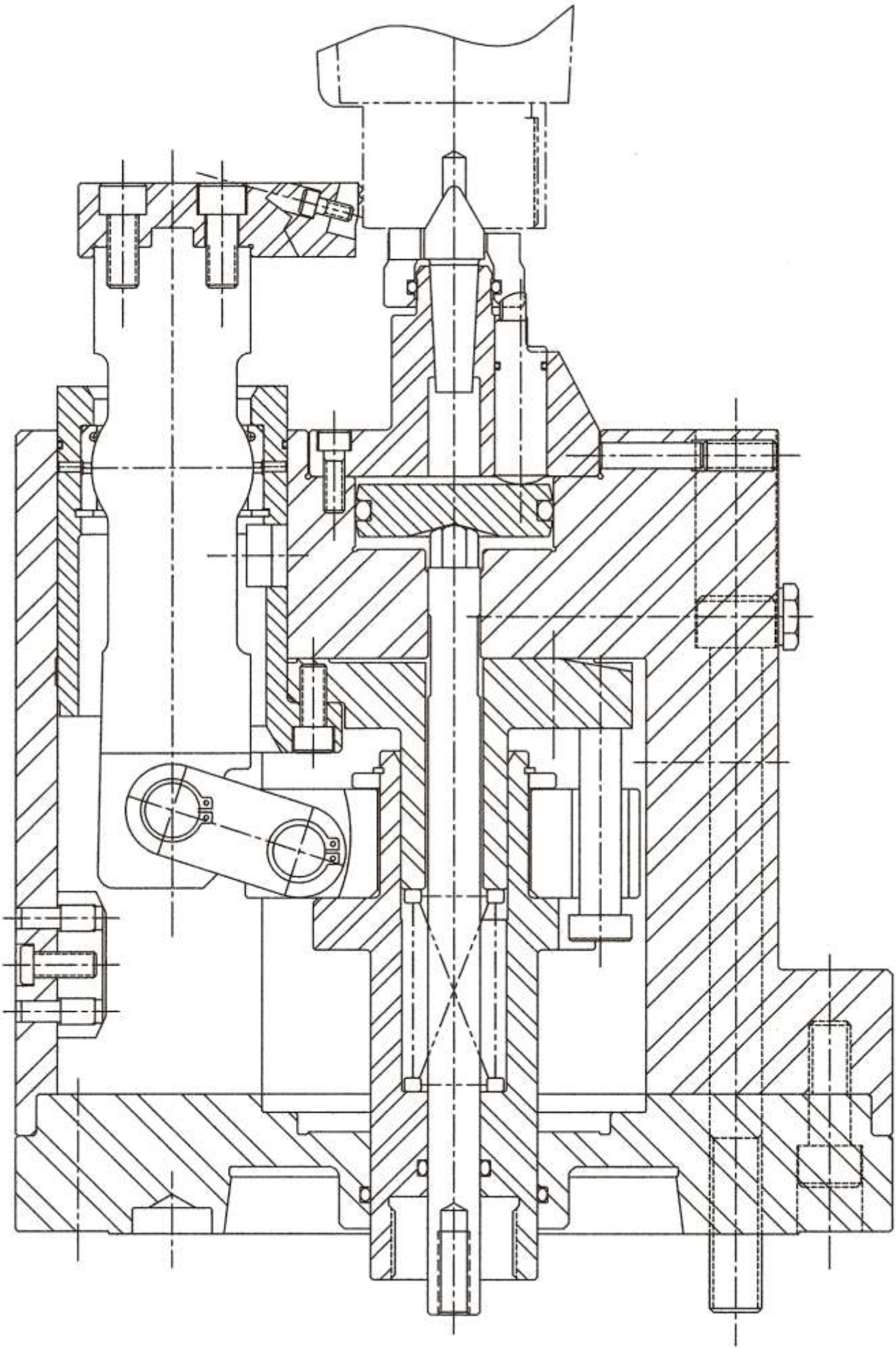

RETRACTABLE DRIVER CHUCK

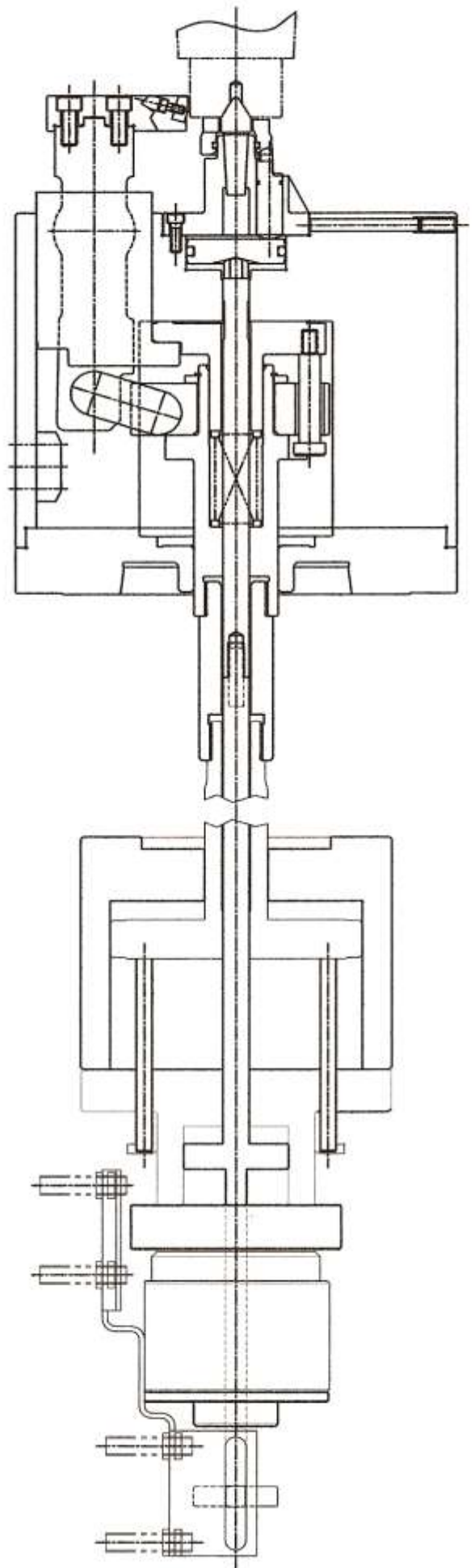
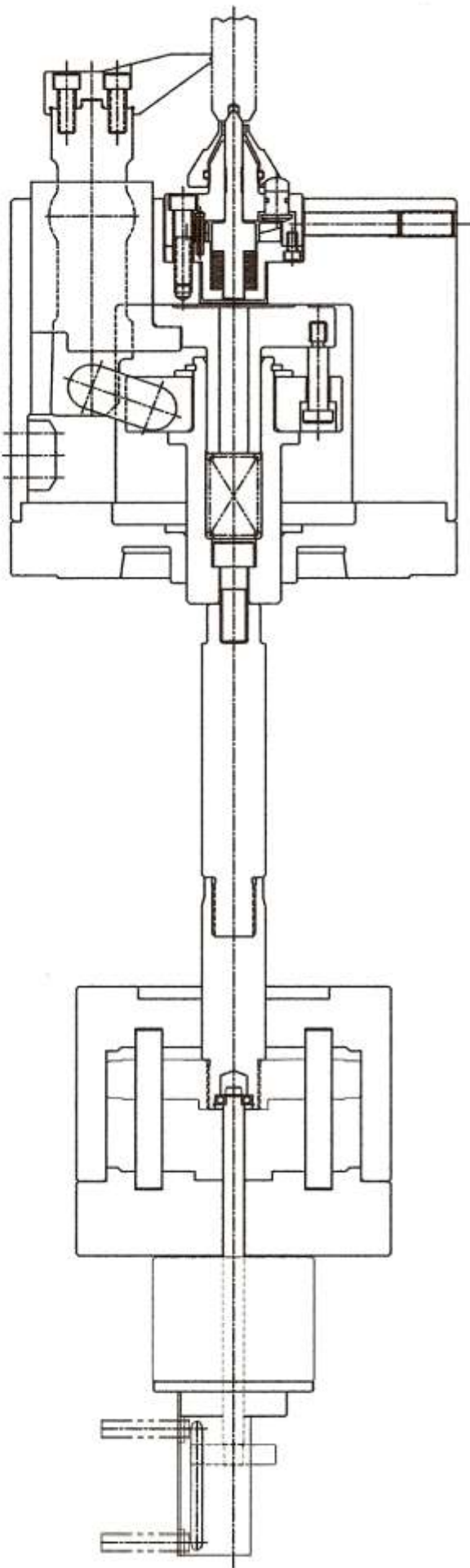

RETRACTABLE JAW / DRIVER APPLICATIONS
SOLID CENTER WITH POWERED DRIVER BLADES

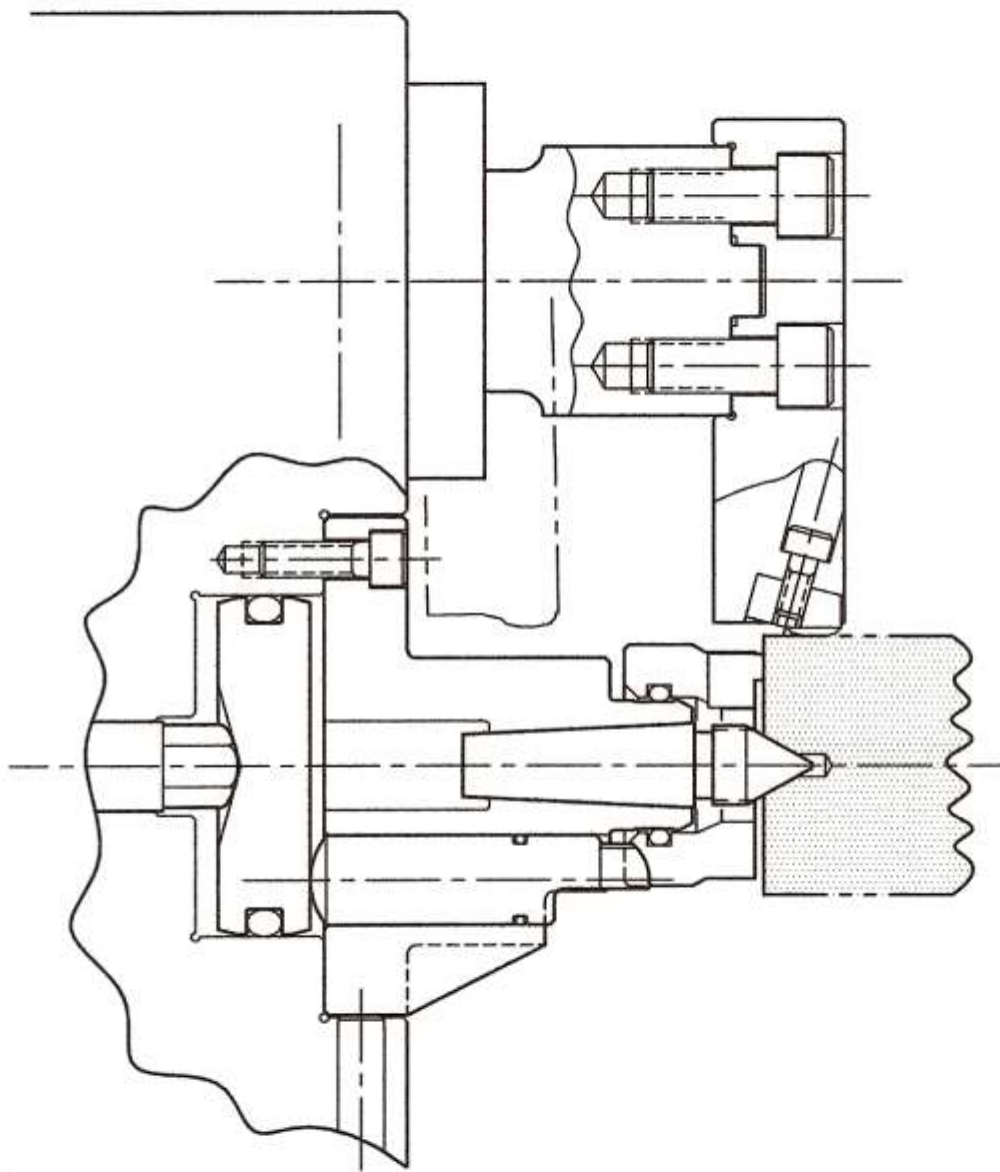

DUAL PISTON
CYLINDER REQUIRED
STROKE DETECTION
RECOMMENDED

RETRACTABLE JAW / DRIVER APPLICATIONS
SPRING LOADED CENTER WITH FIXED DRIVER BLADES

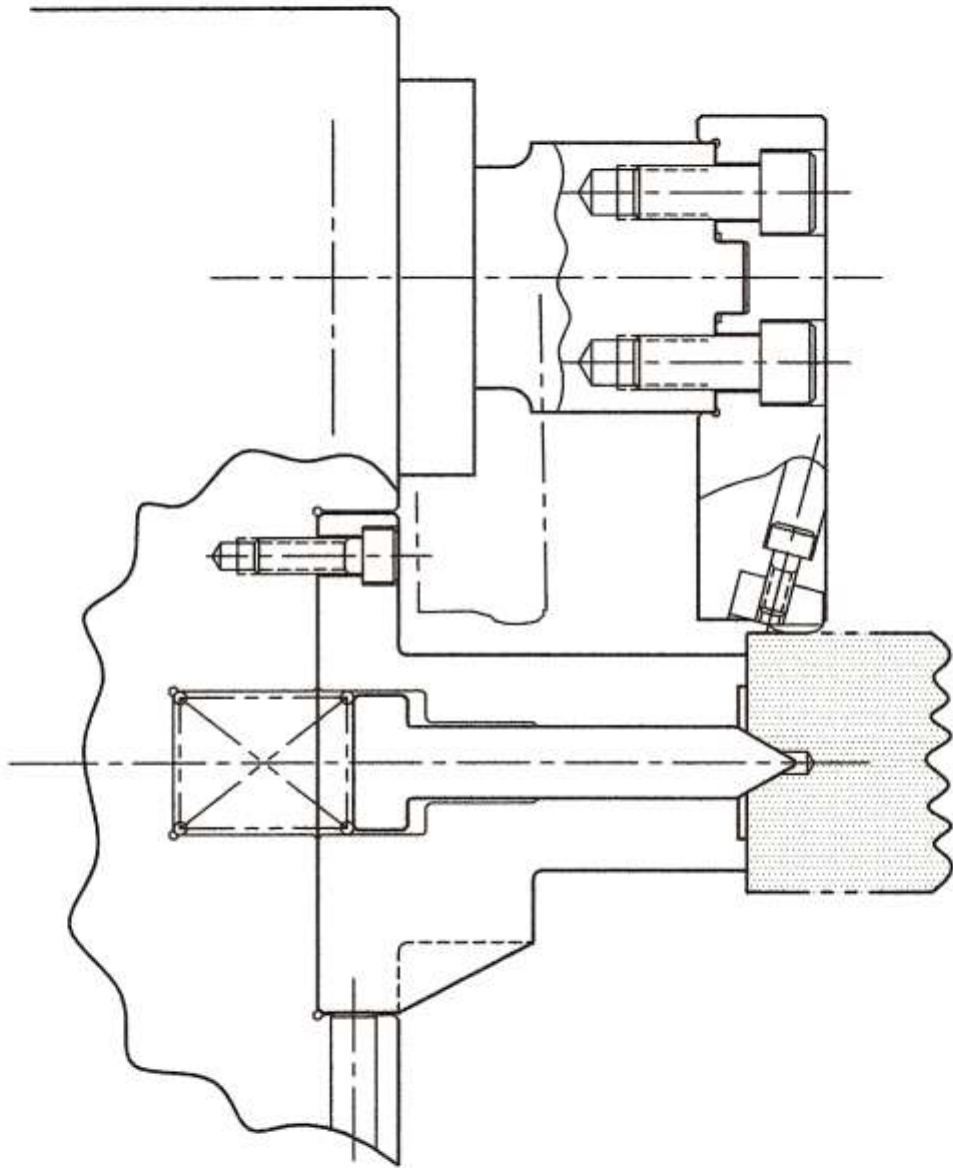

SINGLE PISTON
CYLINDER REQUIRED
STROKE DETECTION
RECOMMENDED

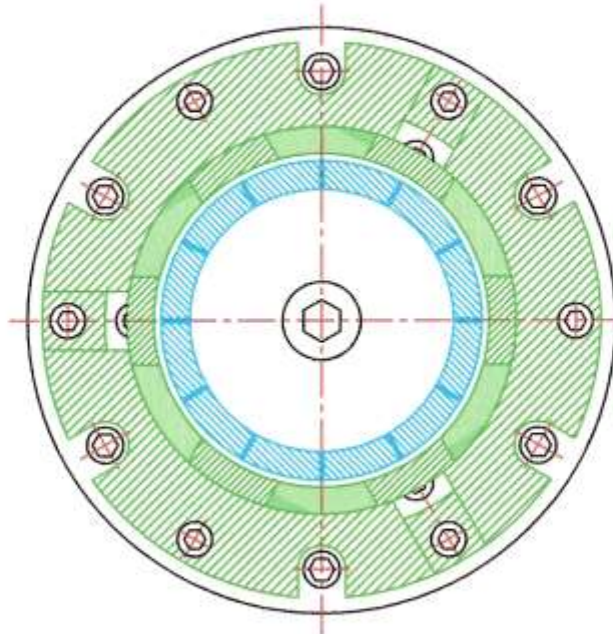
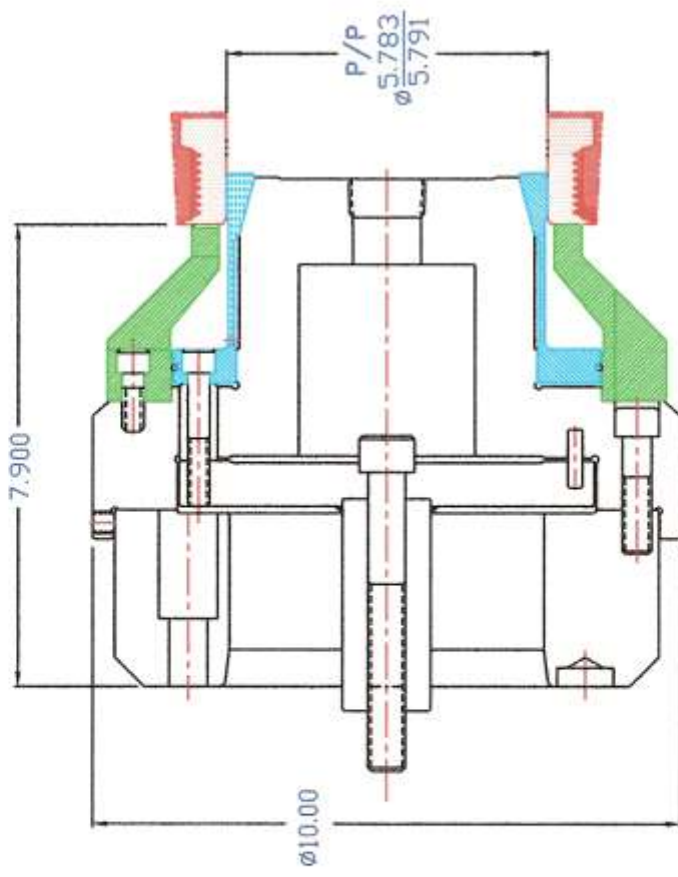

PART NAME: PULLEY (SHEAVE)

OPERATION #20: TURN O.D. AND FACE.

PRODUCT: I.D. GRIP SINGLE TAPER COLLET
 CHUCK ASSEMBLY DRAWBAR OPERATED.

LOCATION: PART GRIPPED AND CENTRALIZED IN I.D.,
 PULL BACK HOLDS PART RIGID AGAINST
 LOCATOR RING.

1870-ICC

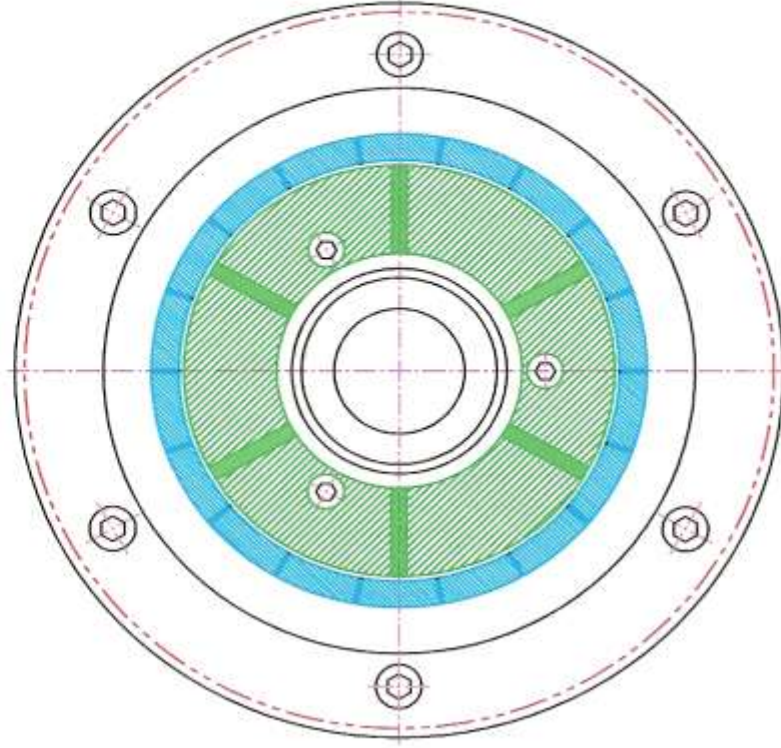
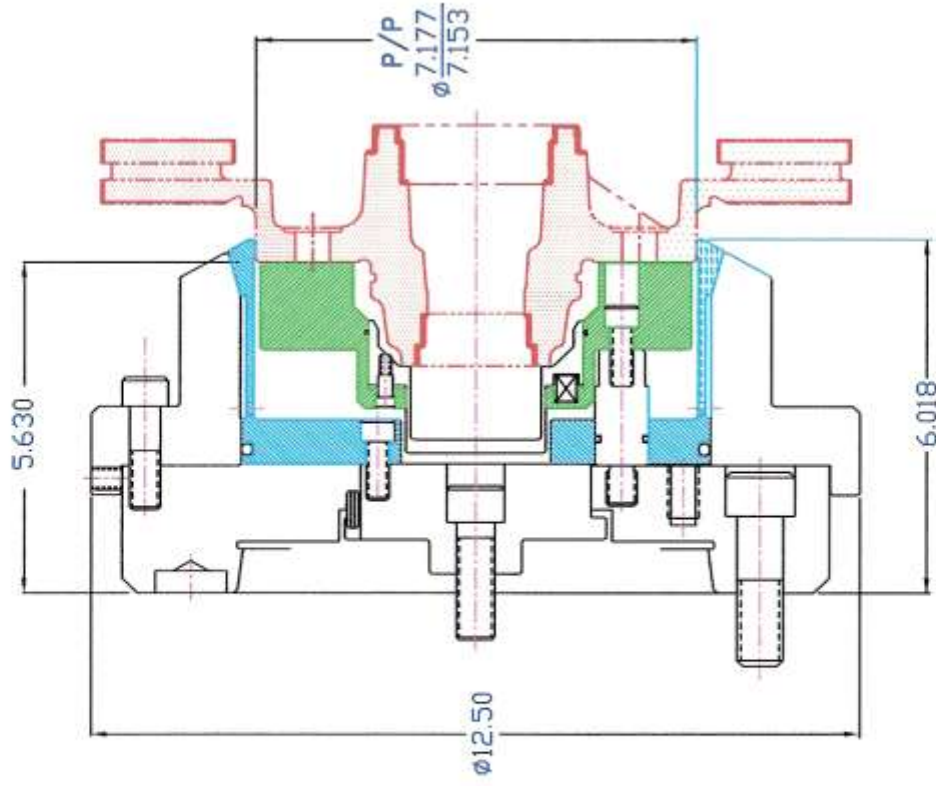

PART NAME: BRAKE PLATE

OPERATION #20: TURN I.D., FACE, INSIDE MOUNTING SURFACE,
FINISH MACHINE BRAKE PLATE SURFACES.

PRODUCT: 12.50" O.D. GRIP LEAF STYLE CENTRALIZING
COLLET CHUCK ASS'Y, DRAWBAR OPERATED.

LOCATION: O.D. COLLET GRIPS ON A PRE-MACHINED DIA.
PULL BACK HOLDS PART RIGID AGAINST
FIXED LOCATOR RING.

2190-ECC

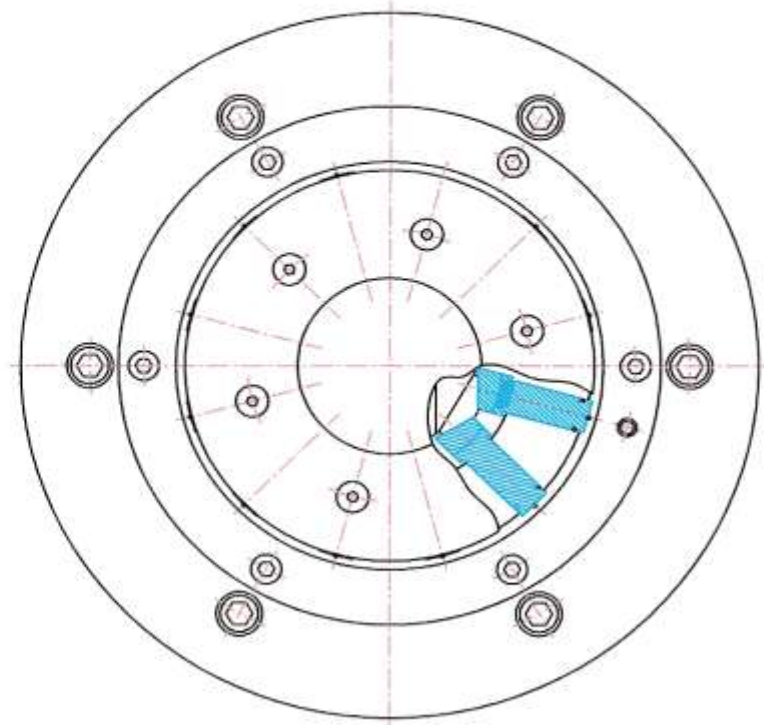
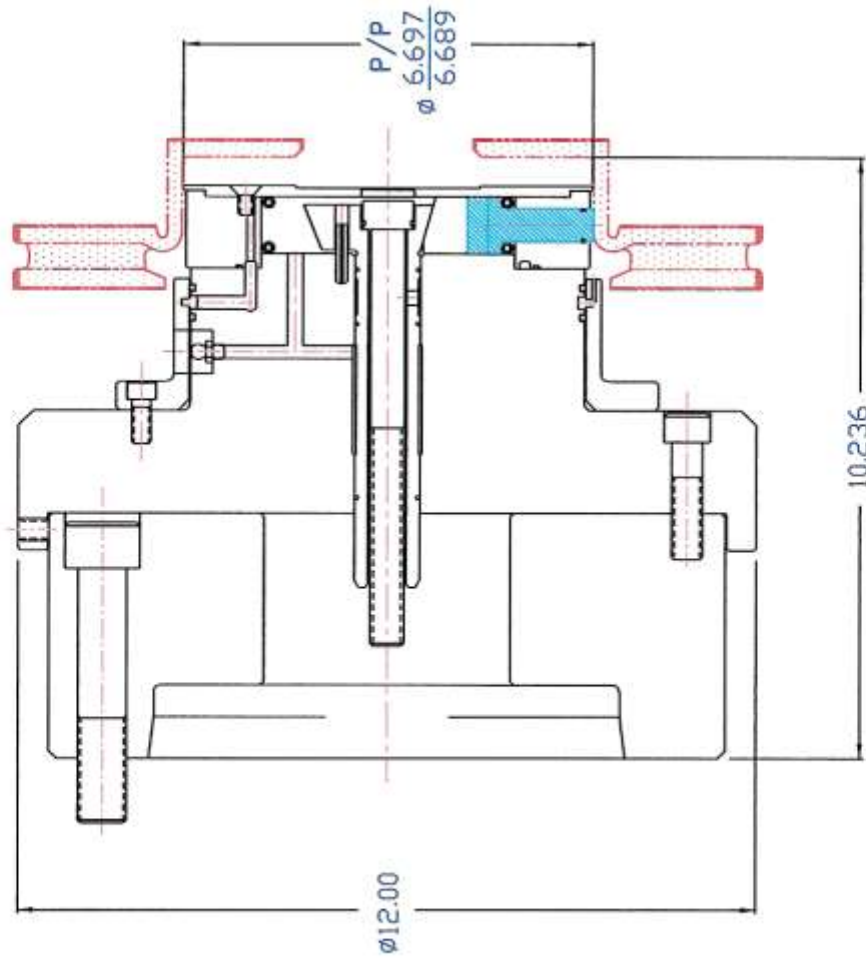

PART NAME:

ROTOR.

OPERATION #30:

TURN I.D., FACE, PILOT BORE & STRADDLE.
 RUN-OUT WITHIN .001 OR LESS.

PRODUCT:

12" NON-DEFORMING PIN ARBOR ASSEMBLY,
 DRAWBAR OPERATED.

LOCATION:

(12) PINS GRIP IN PRE-MACHINED I.D.,
 EQUALIZING GRIP FORCES AND PREVENTING
 PART DISTORTION, ENDWISE LOCATION OFF
 OF LOADER MECHANISM.

2147-PA



ULTRA-GRIP
 INTERMEDIATE
 the ultimate in work holding

8175 RICHARDSON ROAD, VALLES LAKE, MICHIGAN 49790

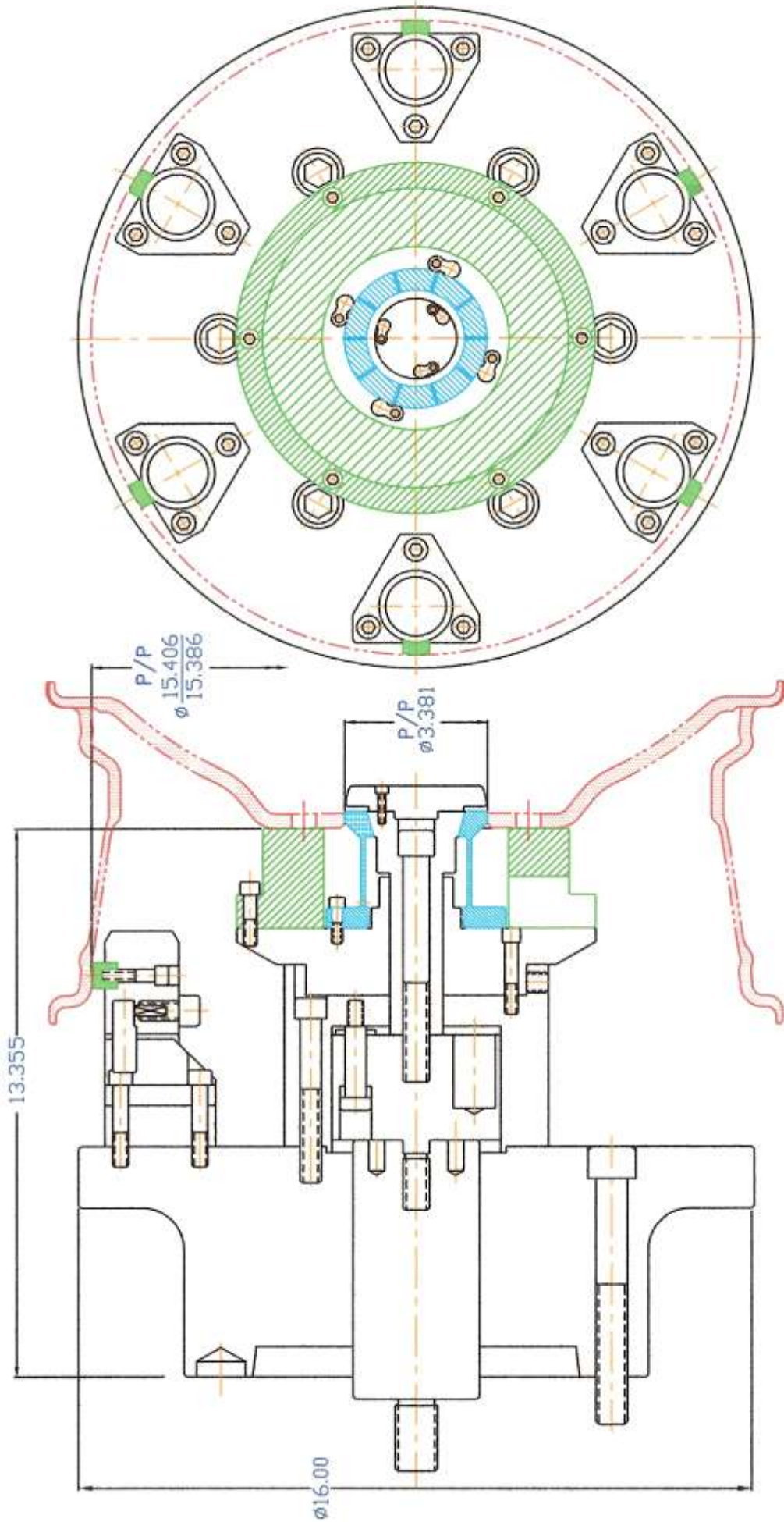

PART WHEEL RIM AND SPIDER ASSY.

OPERATION: TURN O.D. AND BACKFACE

PRODUCT: LEAF STYLE COLLET ARBOR ASSEMBLY WITH
(6) CENTRIFUGAL DAMPENER ASSEMBLIES.

LOCATION: PART GRIPPED AND CENTRALIZED IN I.D. AND
END LOCATION OFF FIXED LOCATOR RING.

1ST CHUCKING OPERATION

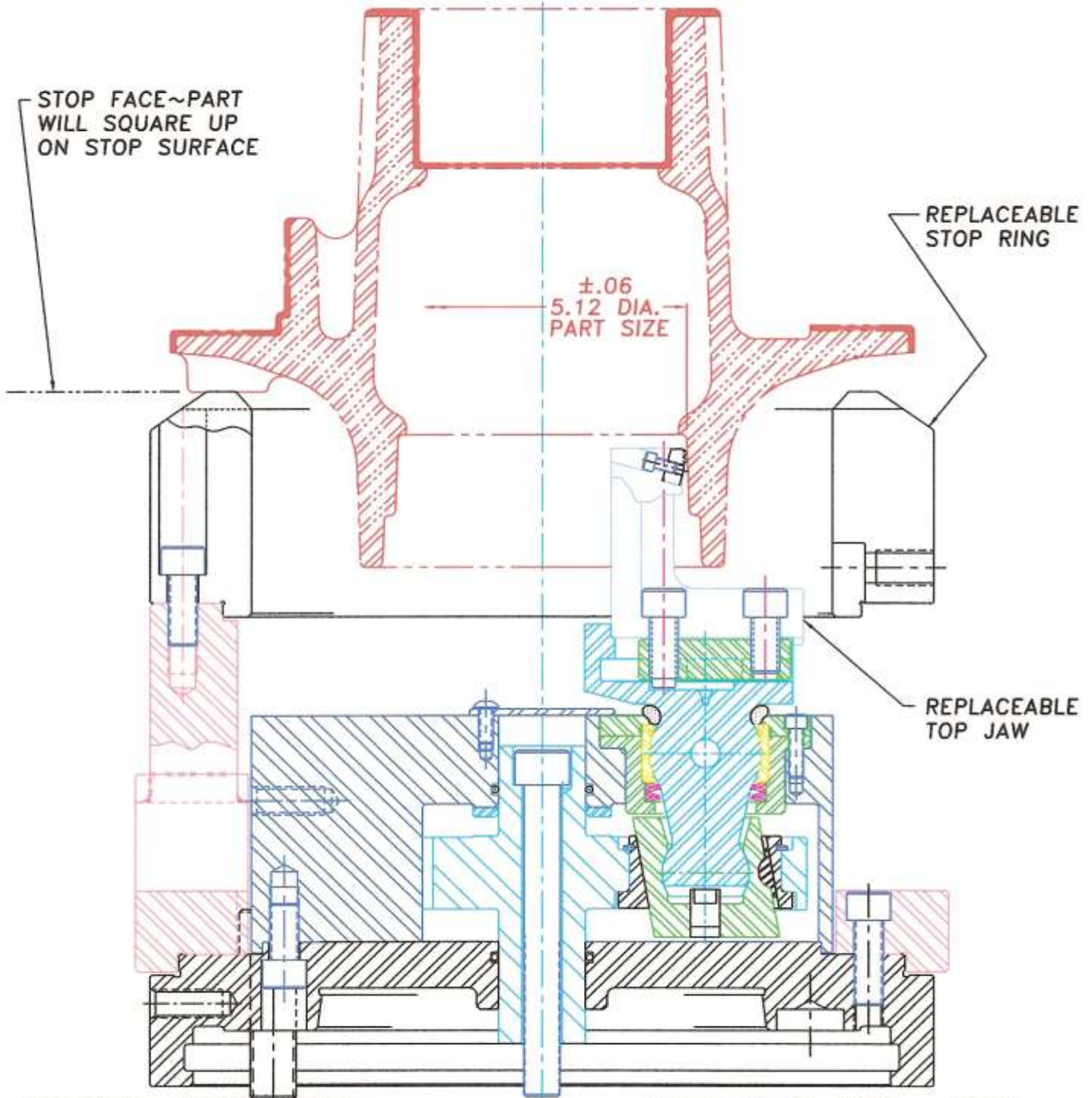

MACHINE: MODEL PUMA
2SP - 15 TWIN
SPINDLE VERTICAL

PART NAME: HUB - REAR
OPERATION: BORE, FACE AND
TURN O.D.

ULTRA-GRIP DRAWBAR OPERATED 10" CENTRALIZING POWER CHUCK

2ND CHUCKING OPERATION

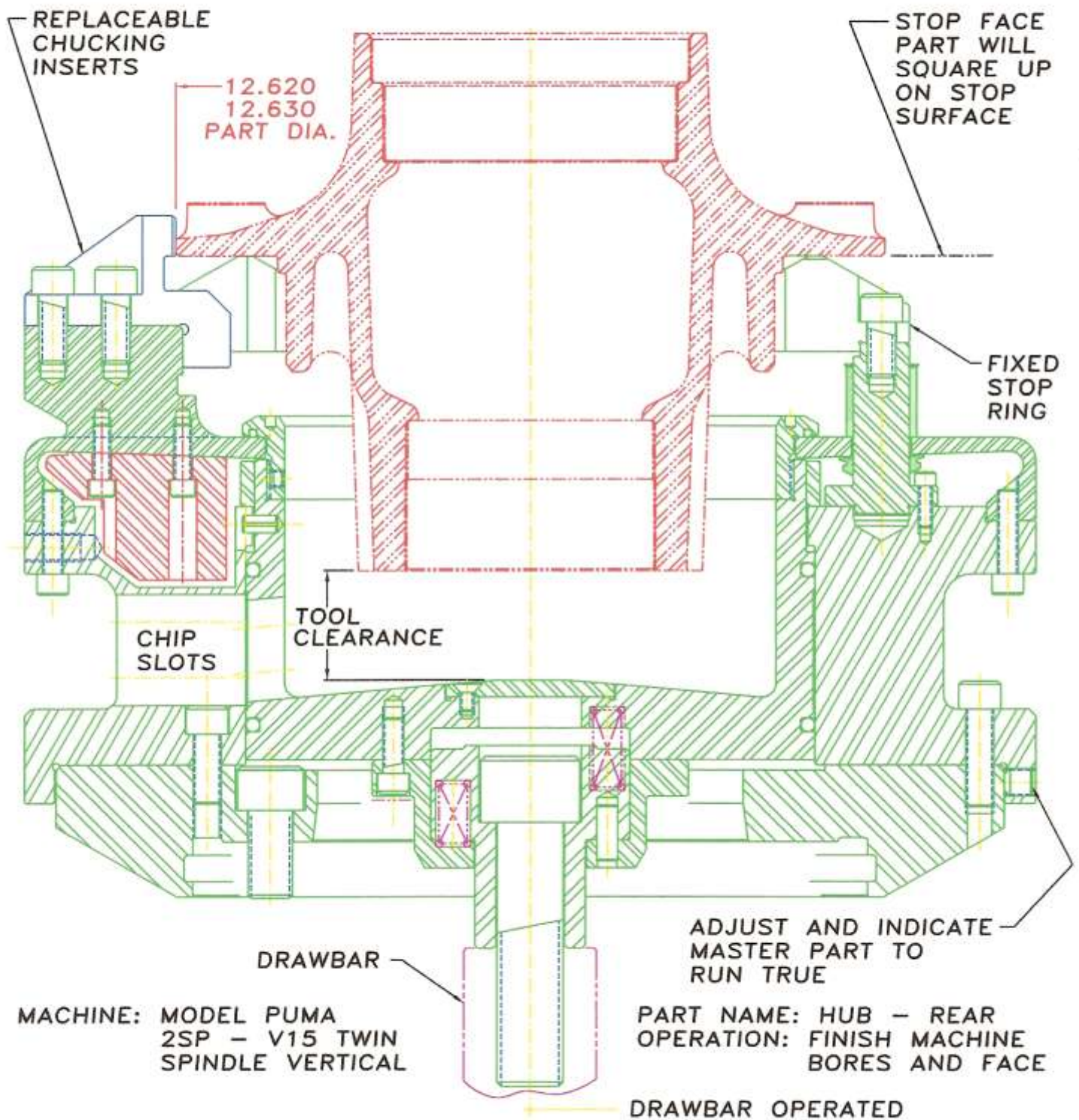

ULTRA-GRIP DRAWBAR OPERATED
18" DIAPHRAGM CHUCK ASSEMBLY

2ND CHUCKING OPERATION

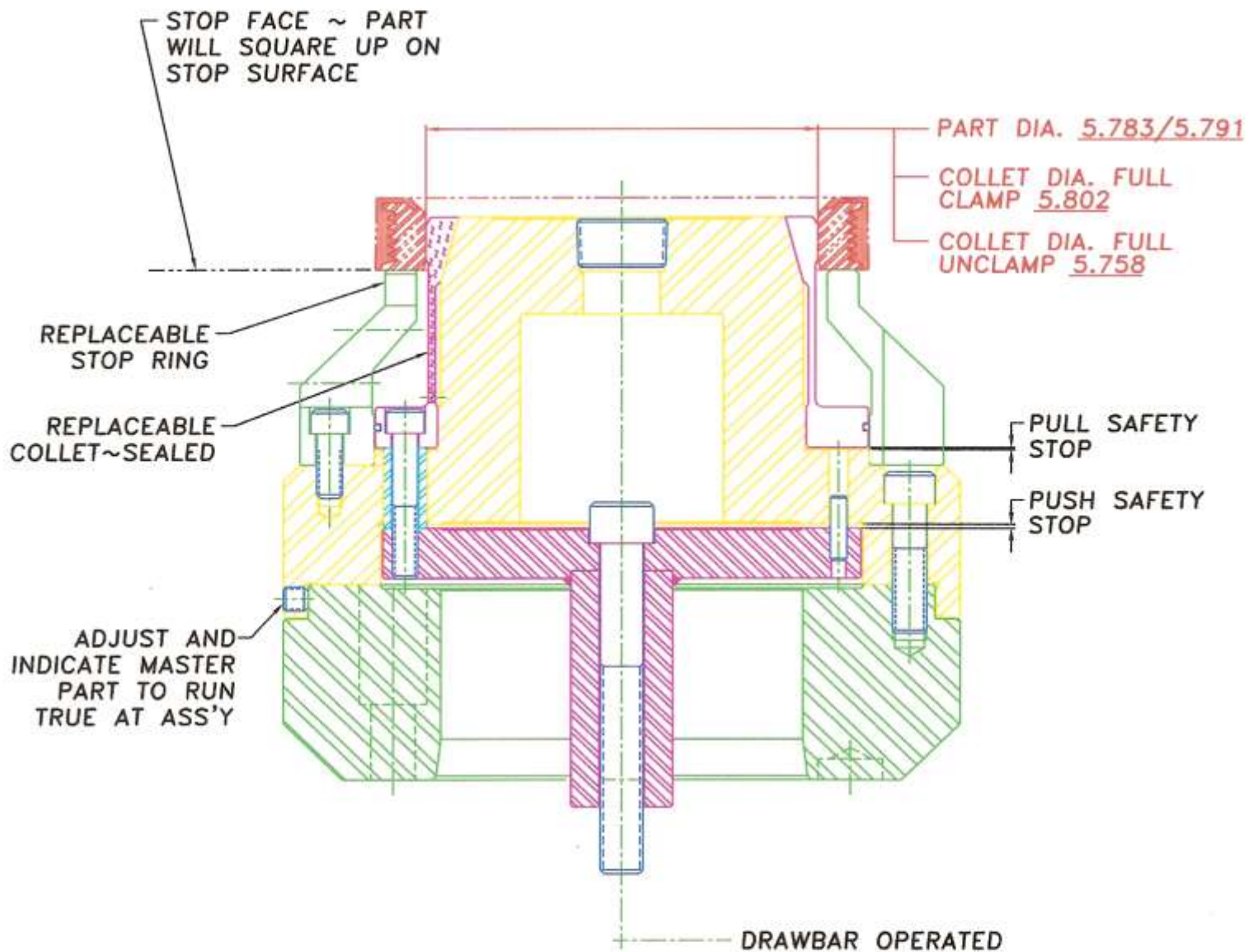

MACHINE: MODEL PUMA 10-2SP
HORIZONTAL TWIN SPINDLE

PART NAME: RING - INERTIA
OPERATION: TURN, GROOVE AND FACE

ULTRA-GRIP DRAWBAR OPERATED COLLET ASSEMBLY

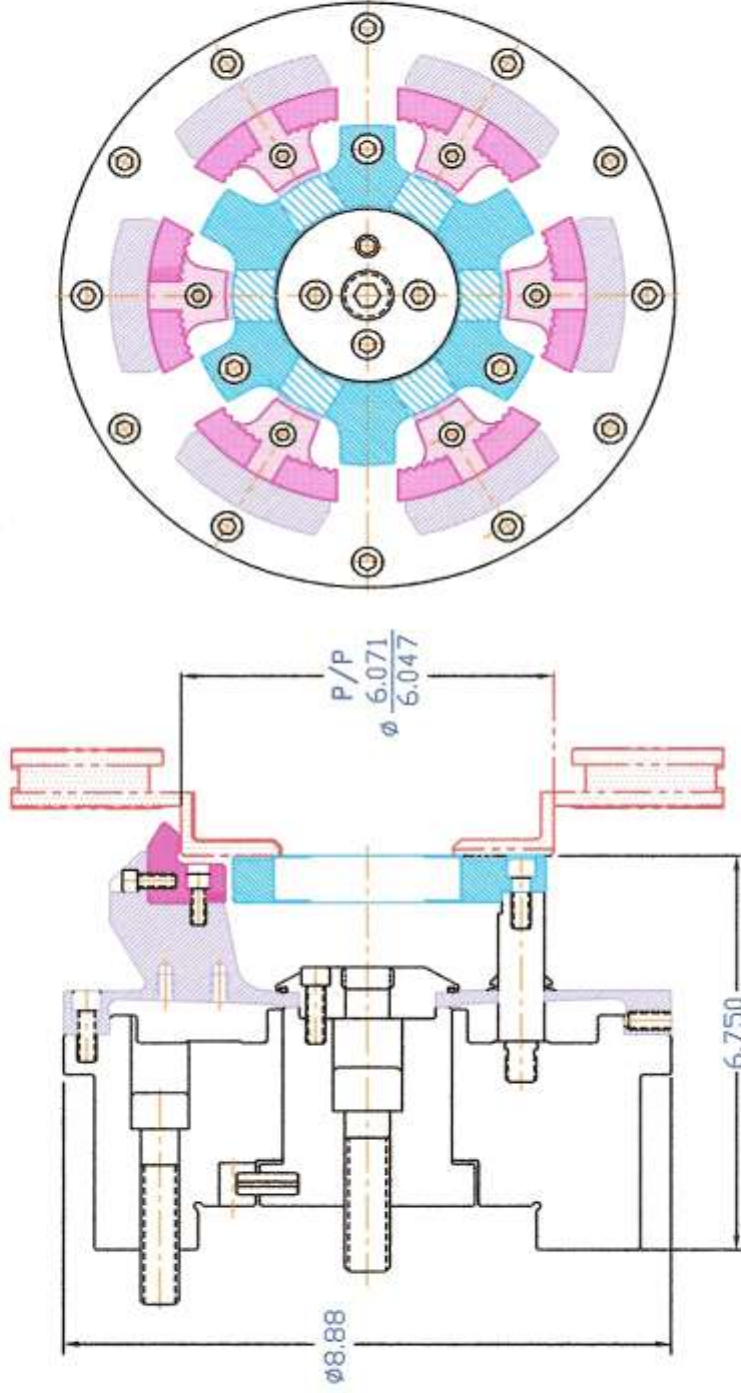

PART NAME:

ROTOR.

OPERATION

FINISH TURN HAT FACE, BORE &
STRADDLE FACE BRAKE SURFACES.
10.00" (6) JAW DIAPHRAGM CHUCK
ASSEMBLY, DRAWBAR OPERATED.
SERRATED JAWS GRIP ON CAST O.D.,
PULL BACK HOLDS PART RIGID
AGAINST LOCATOR RING.

PRODUCT:

LOCATION:

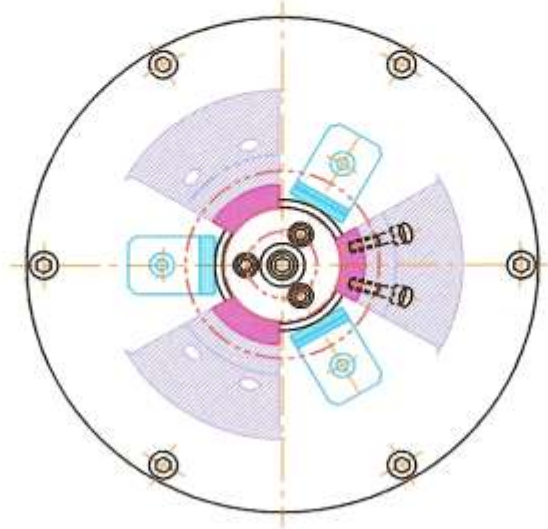
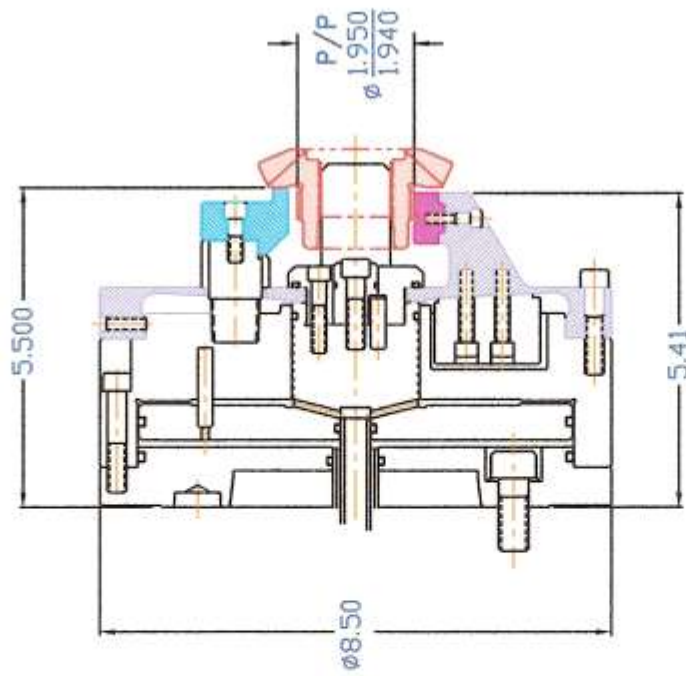

PART NAME: DIFFERENTIAL SIDE GEAR

OPERATION:	FINISH HARD TURNING, C-BORE AND U-CUT
PRODUCT:	8.50" (3-JAW) EXTERNAL PUSH-PULL DIAPHRAGM CHUCK ASSEMBLY, AIR OPERATED.
LOCATION:	JAWS GRIP ON O.D. AND PULL PART BACK AGAINST (3) LOCATOR BLOCKS.

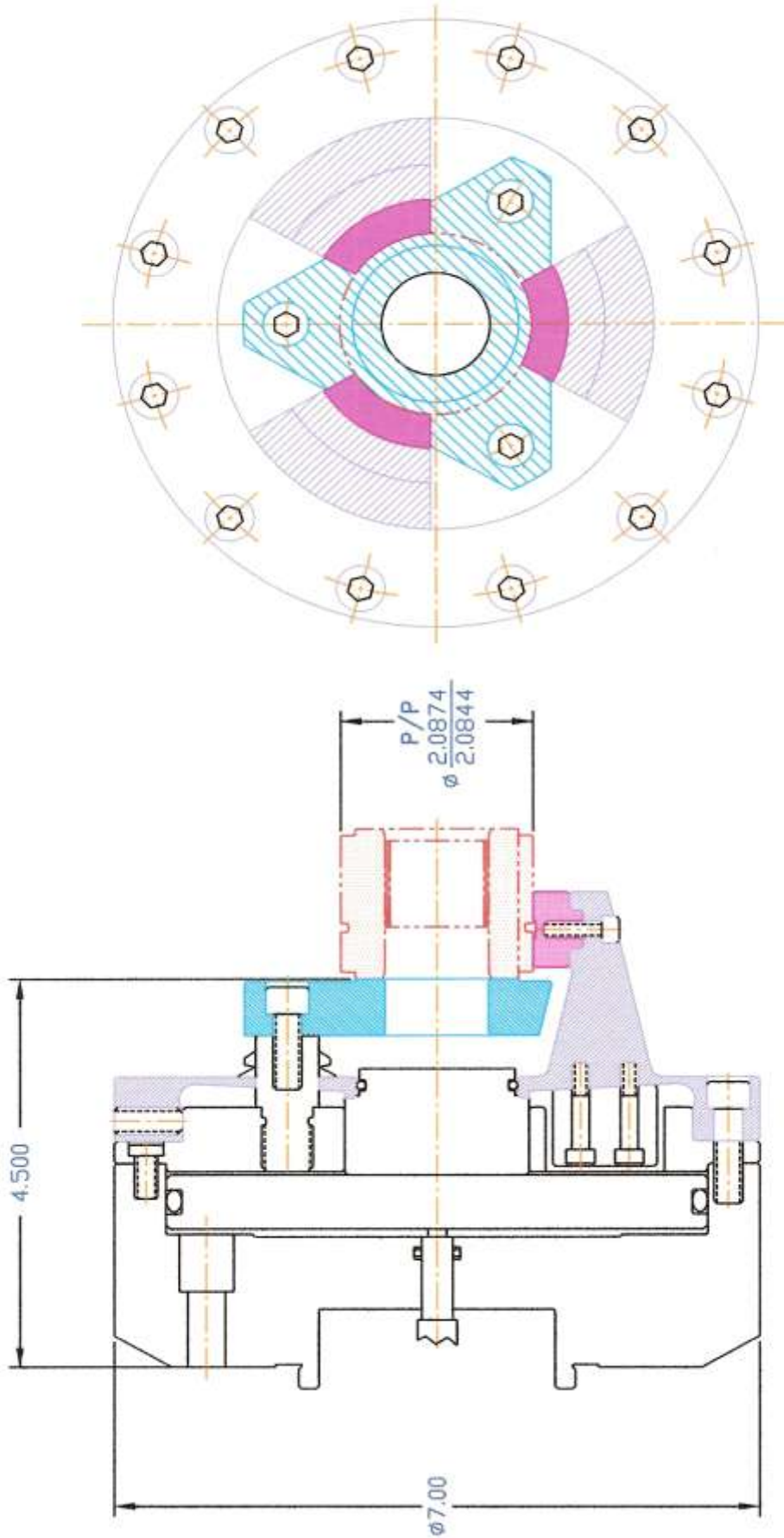

PART NAME: TRANS OVERDRIVE SUN GEAR

OPERATION: BORE BUSHING I.D.

PRODUCT: 7.00" (3-JAW)O.D. GRIP DIAPHRAGM

CHUCK ASSEMBLY, AIR OPERATED.

LOCATION: JAWS GRIP&CENTER PART ON O.D. AND PULL PART
BACK AGAINST FIXED LOCATOR RING.

1607-DCK



the ultimate in work holding
855 RICHARDSON ROAD, VALLEY LAKE, ILLINOIS 60094

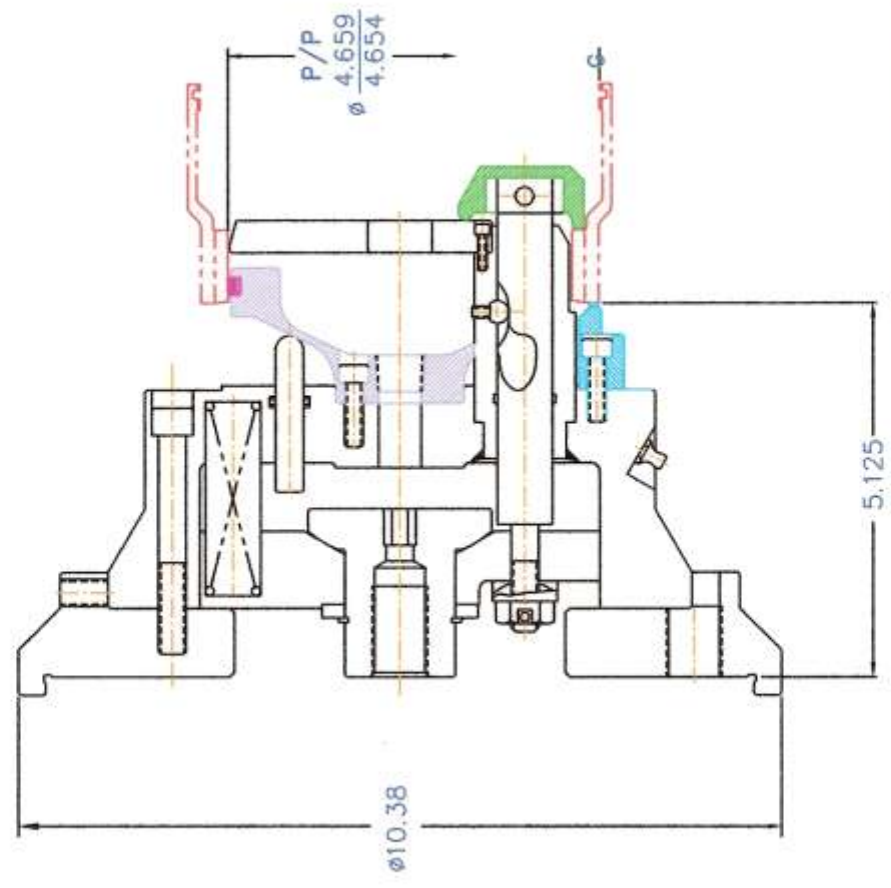
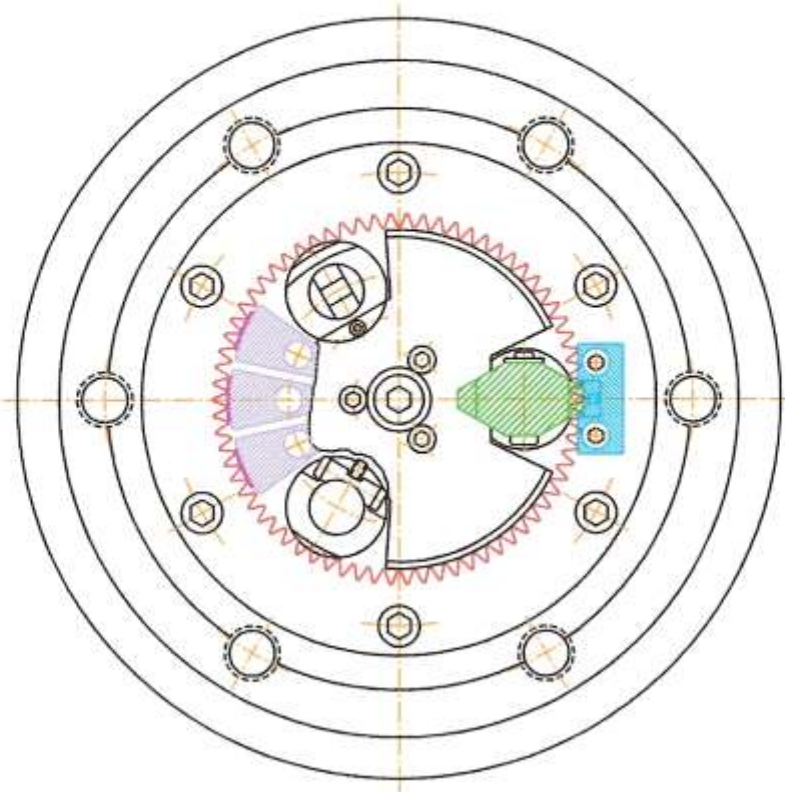

PART NAME: GEAR TRANS. REAR RING

- OPERATION:** GRIND ID ROUND WITHIN .002 OR BETTER
- PRODUCT:** (9) JAW ID GRIP DIAPHRAGM TYPE CHUCK DRAWBAR OPERATED WITH (3) TWIST CLAMPS AND STOPS.
- LOCATION:** PART IS LIGHTLY CENTERED WITH DIAPHRAGM THEN FACE CLAMPED AGAINST LOCATORS (THIS MINIMIZES PART DISTORTION)

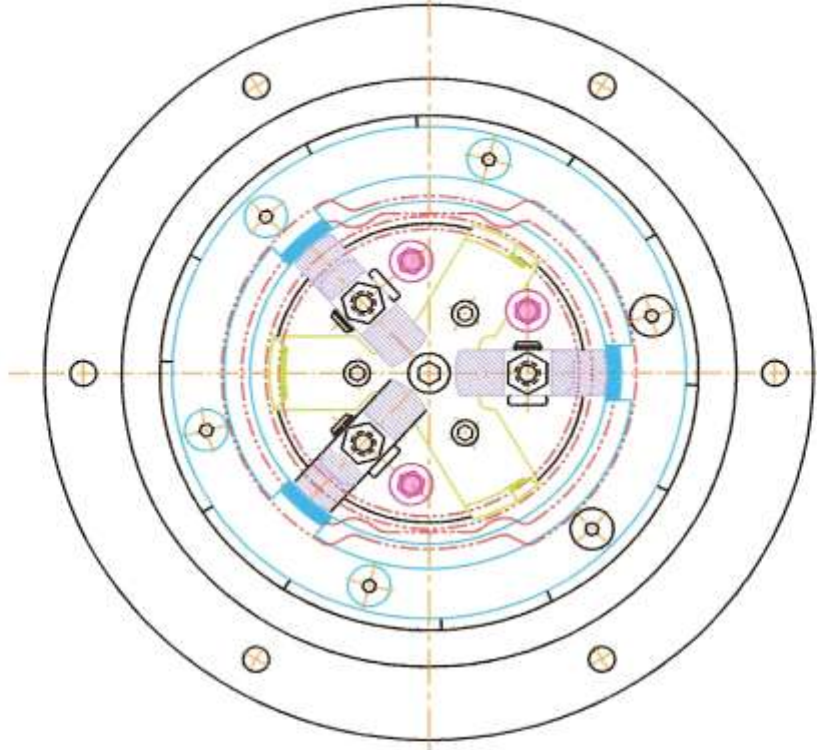
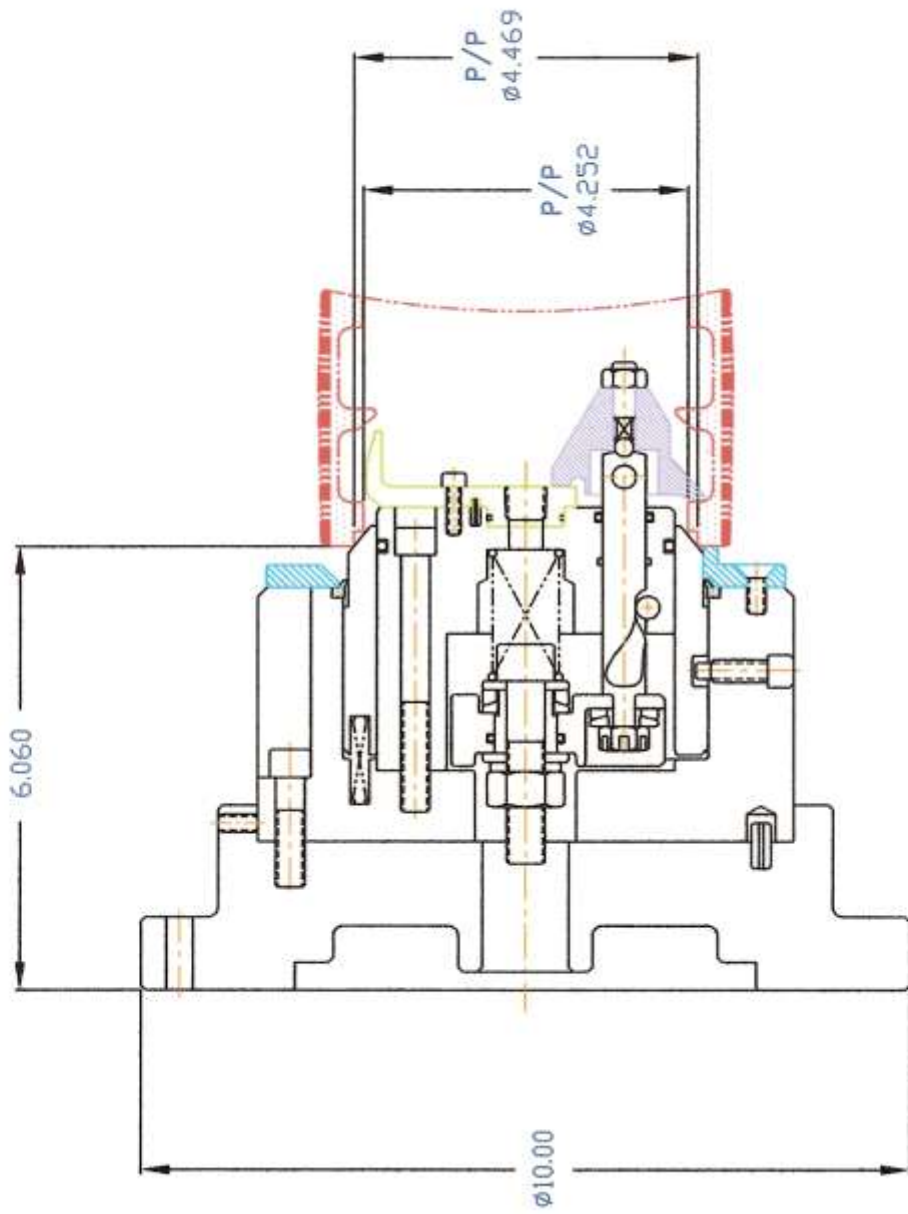

PART NAME: PISTON

OPERATION: GRIND ELLIPTICAL O.D.

PRODUCT: ULTRA-GRIP TWIST FINGER STYLE FACE
CLAMP FIXTURE WITH CENTRALIZING
TAPERED LOCATING RING.

LOCATION: PART IS CENTERED BY TAPERED RING
AND CLAMPED ON INSIDE CAVITY
OF PISTON.

1704-FCC

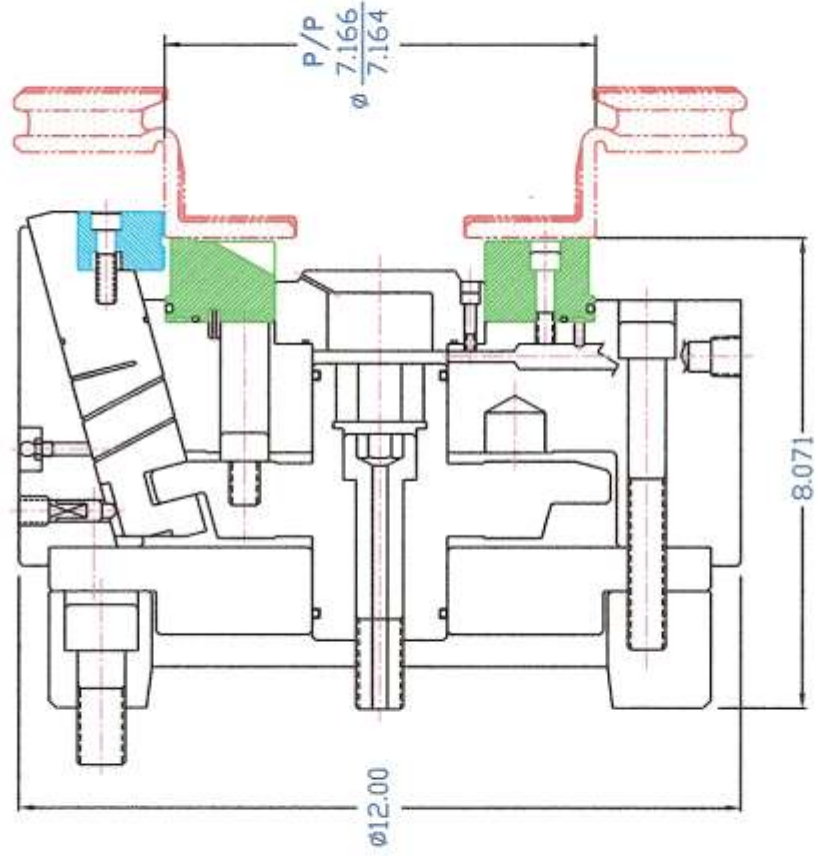
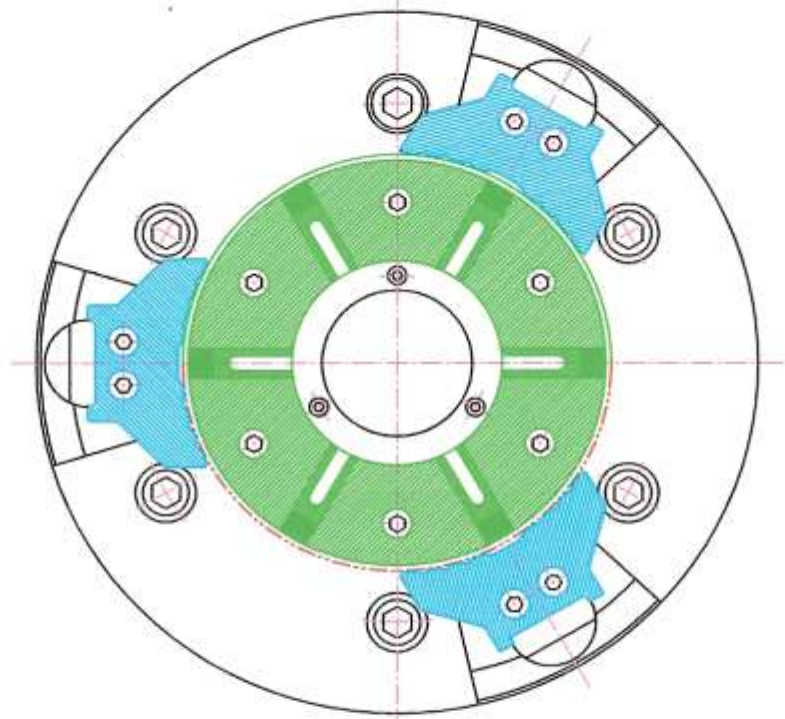

PART NAME: ROTOR.

OPERATION #20: TURN I.D., FACE & CHAMFER.
 RUN-OUT OF .001 OR LESS.

PRODUCT: 12" (3) JAW O.D. GRIP CENTRALIZING
 POWER PIN CHUCK ASSEMBLY.

LOCATION: JAWS GRIP ON PRE-MACHINED O.D.
 PULL BACK HOLDS PART RIGID
 AGAINST FIXED LOCATOR RING.